

# HIGH PRESSURE FLANGE GATE VALVE

## 高中压法兰闸阀

### 结构优势与特点 Structural advantages and characteristics

- 1、符合国内外先进标准的要求，密封可靠，性能优良，造型美观。
  - 2、闸板、阀座密封面用铁基合金堆焊或司太立 (stellite) 钴基硬质合金堆焊而成，耐磨、耐高温、耐腐蚀、抗擦伤性能好、使用寿命长。
  - 3、采用楔式弹性闸板结构，中大口径设置滚动轴承，开关灵活，启闭轻松。
  - 4、阀杆经调质及表面氮化处理，有良好的抗腐蚀性，抗擦伤性和耐磨性。
  - 5、可采用各种配管法兰标准及法兰密封面型式，满足各种工程需要及用户要求。
  - 6、阀体材料品种齐全，填料、垫片可根据实际工况或用户要求合理选配，能适用于各种压力、温度及介质工况。
- 1、Meets the domestic and foreign advanced standard requirement, the seal is reliable, the performance is fine, handsome appearance.
  - 2、The damper plate, the valve seat packing surface is too vertical (stellite) with the iron-base alloy built-up welding or the department the cobalt base hard alloy built-up welding to become, wear-resisting, thermostable, anti-corrosive, the anti-abrasion performance is good, the service life is long.
  - 3、Using wedge-type flexible gate structure, medium and large caliber set bearings, switches flexible, open and close easily.
  - 4、Stem quenched and the nitrogen treatment, with good corrosion resistance, scratch resistance and wear resistance.
  - 5、Can be used with a variety of standard pipe flanges and flange sealing surface types to meet various project needs and user requirements.
  - 6、Valve body materials, variety, packing, gasket can be based on actual working conditions or the user requests a reasonable option, can be applied to all kinds of pressure, temperature and medium conditions.

### 标准与规范 Standards and norms

设计与制造 Design and Manufacture	结构长度 Structure Length	压力-温度等级 Pressure-temperature rating	连接法兰 Connection flange	试验与检验 Test and Inspection
GB 12234	GB 12221	GB/T 12224	JB/T 79.1-2-94 GB 9113-2009 HG 20592 ~ 20635	JB/T 9092-1999 GB 13927-2005

### 性能参数 Performance parameter

序号	项目名称	项目名称					
		PN16	PN25	PN40	PN64	PN100	PN160
1	公称压力PN(MPa)	1.6	2.5	4.0	6.4	10	16
2	壳体强度试验压力 Shell strength test pressure(MPa)	常温下公称压力的1.5倍 1.5 Times the nominal pressure at room temperature					
3	高压密封试验压力 High-pressure sealing Test pressure(MPa)	常温下公称压力的1.1倍 1.1 Times the nominal pressure at room temperature					
4	常温下工作压力 Operating pressure at room temperature(MPa)	按GB/T 12224 压力温度额定值 According to GB/T 12224 pressure temperature rating					

### 主要零件材料 Main components material

名称 Name	材料 Material								
阀体/阀盖 Body/Bonnet	CF8	CF3	CF8M	CF3M	WCB	LCB	WC6	WC9	C5
闸板 Wedge	CF8	CF3	CF8M	CF3M	WCB	LCB	WC6	WC9	C5
阀杆 Stem	F304	F304L	F316	F316L	2CR13	F304	F304	F304	F304
阀杆螺母 Stem Nut	铝青铜 Aluminium Bronze								
填料 Packing	PTFE/柔性石墨				石墨 Graphite				
垫片 Gasket	PTFE/金属缠绕垫				石墨 Graphite				
压盖 Gland	CF8	CF3	CF8M	CF3M	WCB	LCB	WC6	WC9	C5
螺栓 Bolt	不锈钢 Stainless Steel				35CrMoA				
螺母 Nut	不锈钢 Stainless Steel				45、35CrMoA				
手轮 Handwheel	铸钢 Cast Steel								

# MEDIUM PRESSURE FLANGE TO MANUAL GATE VALVE

## 中压法兰连接手动闸阀

Z41<sup>10</sup><sub>W</sub><sup>16</sup><sub>H</sub>-<sup>25</sup><sub>40</sub><sup>63</sup>C、I、P、R

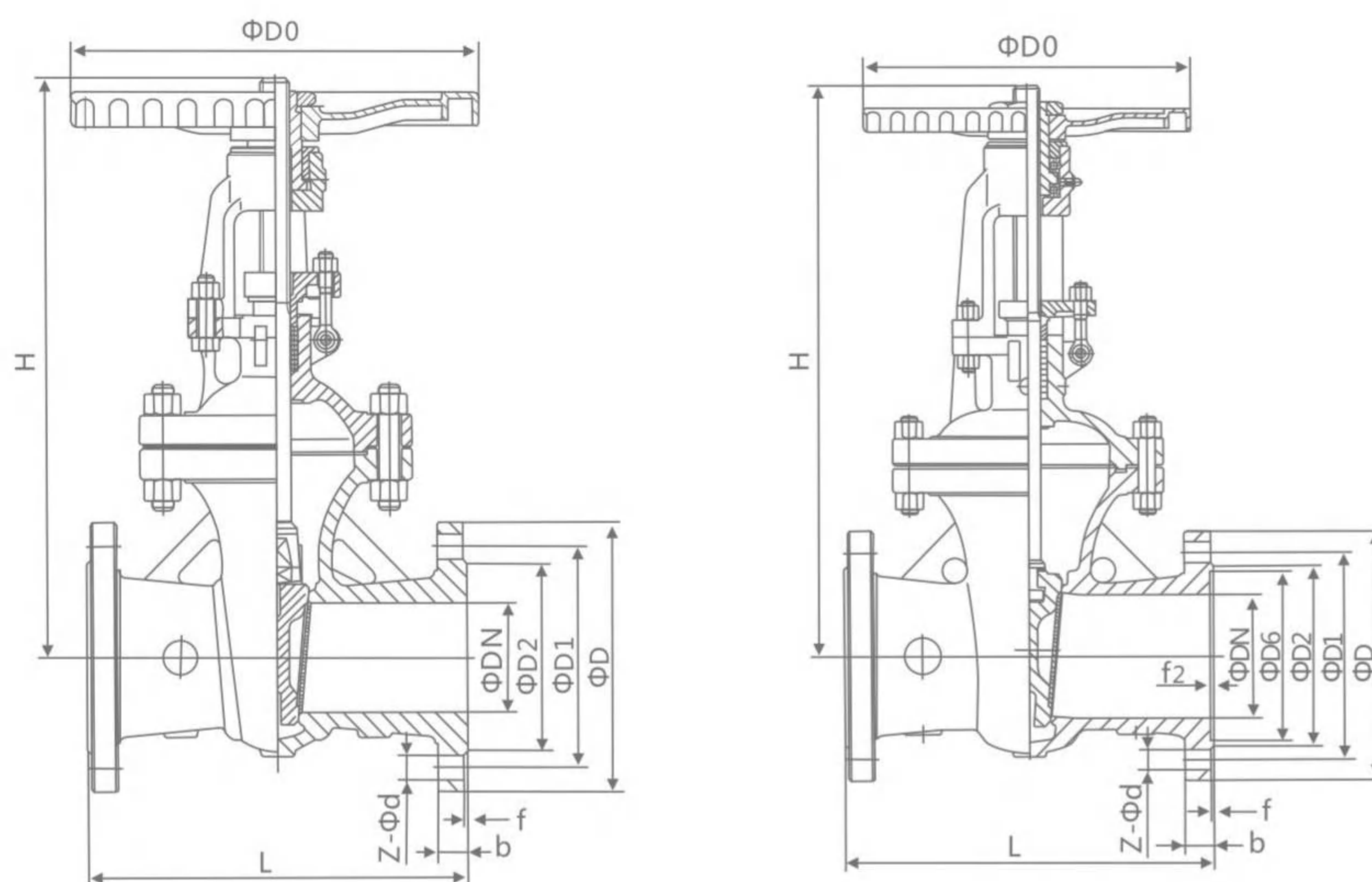

主要外形尺寸及连接尺寸 Main external and connection dimension

JB/T82.1-1994

JB/T79.1-1994

公称压力 PN(MPa)	公称通径 DN(mm)	尺寸Size(mm)								重量 ( kg )
		L	D	D1	D2	b-f	Z-φd	H	D0	
1.0	15	130	95	65	45	12-2	4-φ14	160	100	5
	20	150	105	75	55	14-2	4-φ14	165	100	8
	25	160	115	85	65	14-2	4-φ14	200	125	11
	32	180	135	100	78	16-2	4-φ18	240	125	13
	40	165	145	110	85	16-3	4-φ18	245	135	9.5
	50	180	160	125	100	16-3	4-φ18	286	180	24
	65	195	180	145	120	18-3	4-φ18	320	180	31
	80	210	195	160	135	18-3	4-φ18	373	200	40
	100	230	215	180	155	20-3	8-φ18	428	200	55
	125	255	245	210	185	22-3	8-φ18	513	240	63
	150	280	280	240	210	22-3	8-φ23	582	240	90
	200	330	335	295	265	22-3	8-φ23	730	320	145
	250	380	390	350	320	24-3	12-φ23	897	320	230
	300	420	440	400	368	26-4	12-φ23	1032	400	330
	350	450	500	460	428	26-4	16-φ23	1170	400	460
	400	480	565	515	482	26-4	16-φ25	1330	500	500
	450	510	615	565	532	26-4	20-φ25	1460	500	680
	500	540	670	620	585	28-4	20-φ25	1650	500	960
	600	600	780	725	685	28-5	20-φ30	183	600	1200
700	660	895	840	800	30-5	24-φ30	2120	700	1620	
800	730	1010	950	905	32-5	24-φ34	2420	800	2090	
900	800	1110	1050	1005	34-5	28-φ34	2750	850	3100	
1000	850	1220	1160	1115	34-5	28-φ34	3130	900	4050	
1.6	15	130	95	65	45	14-2	4-φ14	170	120	5
	20	150	105	75	55	14-2	4-φ14	190	140	6.5
	25	160	115	85	65	14-2	4-φ14	205	160	9
	32	180	135	100	78	16-2	4-φ18	270	180	12
	40	200	145	110	85	16-3	4-φ18	290	200	26.5
	50	250	160	125	100	16-3	4-φ18	310	240	29
	65	265	180	145	120	18-3	4-φ18	373	240	33
	80	280	195	160	135	20-3	8-φ18	435	280	45
	100	300	215	180	155	20-3	8-φ18	445	300	63
	125	325	245	210	185	22-3	8-φ18	570	320	108
	150	350	280	240	210	24-3	8-φ23	630	360	134
	200	400	335	295	265	26-3	12-φ23	735	400	192
	250	450	405	355	320	30-3	12-φ25	969	450	273
	300	500	460	410	375	30-4	12-φ25	976	580	379
	350	550	520	470	435	34-4	16-φ25	1120	640	500
	400	600	580	525	485	36-4	16-φ30	1452	640	540
	450	650	640	585	545	40-4	20-φ30	1541	720	870
	500	700	705	650	608	44-4	20-φ34	1880	720	1100
	600	800	840	770	718	48-5	20-φ36	1874	800	1570
	700	900	910	840	788	50-5	24-φ41	2083	800	1870
800	1000	1020	950	898	52-5	24-φ41	2400	850	2500	
900	1100	1120	1050	998	54-5	28-φ41	2950	1000	3620	
1000	1200	1255	1170	1110	56-5	28-φ48	3245	1000	4550	

# MEDIUM PRESSURE FLANGE TO MANUAL GATE VALVE

## 中压法兰连接手动闸阀

主要外形尺寸及连接尺寸 Main external and connection dimension

JB/T79.1-1994

公称压力 PN(MPa)	公称通径 DN(mm)	尺寸Size(mm)								重量 (kg)
		L	D	D1	D2	b-f	Z-Φd	H	D0	
2.5	15	130	95	65	45	16-2	4-Φ14	170	120	5.5
	20	150	105	75	55	16-2	4-Φ14	190	140	7
	25	160	115	85	65	16-2	4-Φ14	205	160	11
	32	180	135	100	78	18-2	4-Φ18	270	180	14
	40	200	145	110	85	18-3	4-Φ18	310	200	20
	50	250	160	125	100	20-3	4-Φ18	358	240	34
	65	265	180	145	120	22-3	8-Φ18	373	240	36
	80	280	195	160	135	22-3	8-Φ18	435	280	50
	100	300	230	190	160	24-3	8-Φ23	500	300	69
	125	325	270	220	188	28-3	8-Φ25	614	320	116
	150	350	300	250	218	30-3	8-Φ25	674	360	141
	200	400	360	310	278	34-3	12-Φ25	811	400	192
	250	450	425	370	332	36-3	12-Φ30	969	450	207
	300	500	485	430	390	40-4	16-Φ30	1145	580	350
	350	550	550	490	448	44-4	16-Φ34	1280	640	560
	400	600	610	550	505	48-4	16-Φ34	1452	640	650
	450	650	660	600	555	50-4	20-Φ34	1541	720	910
	500	700	730	660	610	52-4	20-Φ41	1676	720	1166
600	800	840	770	718	56-5	20-Φ41	1874	800	1650	
700	900	955	875	815	60-5	24-Φ48	2083	800	1980	
800	1000	1070	990	930	64-5	24-Φ48	2400	950	2740	
900	1100	1180	1090	1025	66-5	28-Φ54	2950	1000	3900	
1000	1200	1305	1210	1140	68-5	28-Φ58	3245	1000	4850	

主要外形尺寸及连接尺寸 Main external and connection dimension

JB/T79.2-1994

公称压力 PN(MPa)	公称通径 DN(mm)	尺寸Size(mm)										重量 (kg)
		L	D	D1	D2	D6	b-f	f1	Z-Φd	H	D0	
4.0	15	130	95	65	45	40	16-2	4	4-14	135	120	6
	20	150	105	75	55	51	16-2	4	4-14	190	140	8
	25	160	115	85	65	58	16-2	4	4-14	205	160	12
	32	180	135	100	78	66	18-2	4	4-18	270	180	15
	40	200	145	110	85	76	18-3	4	4-18	310	200	31
	50	250	160	125	100	88	20-3	4	4-18	371	280	34
	65	280	180	145	120	110	22-3	4	8-18	391	280	39
	80	310	195	160	135	121	22-3	4	8-18	455	320	52
	100	350	230	190	160	150	24-3	4.5	8-23	551	360	80
	125	400	270	220	188	176	28-3	4.5	8-25	628	400	127
	150	450	300	250	218	204	30-3	4.5	8-25	708	400	154
	200	550	375	320	282	260	38-3	4.5	12-30	885	450	263
	250	650	445	385	345	313	42-3	4.5	12-34	906	560	368
	300	750	510	450	408	364	46-4	4.5	16-34	1203	640	547
	350	850	570	510	465	422	52-4	5	16-34	1341	640	679
	400	950	655	585	535	474	58-4	5	16-41	1492	720	953
	500	1150	755	670	612	576	62-4	5	20-48	1627	/	1073
	600	1350	890	795	730	678	62-5	6	20-54	1925	/	1490
700	1450	995	900	835	768	68-5	6	24-54	2310	/	2640	
800	1650	1135	1030	960	876	76-5	6	24-58	2600	/	3239	
6.3	15	170	105	75	55	40	18-2	4	4-14	140	100	7
	20	190	125	90	68	51	20-2	4	4-18	140	100	9
	25	210	135	100	78	58	22-2	4	4-18	215	180	12
	32	230	150	110	82	66	24-2	4	4-23	270	180	16
	40	240	165	125	95	76	24-3	4	4-23	345	200	32
	50	250	175	135	105	88	26-3	4	4-23	470	200	39
	65	280	200	160	130	110	28-3	4	8-23	520	250	43
	80	310	210	170	140	121	30-3	4.5	8-23	570	300	60
	100	350	250	200	168	150	32-3	4.5	8-25	700	300	89
	125	400	295	240	202	176	36-3	4.5	8-30	780	350	140
	150	450	340	280	240	204	38-3	4.5	8-34	850	350	207
	200	550	405	345	300	260	44-3	4.5	12-34	1035	400	325
	250	650	470	400	352	313	48-3	4.5	12-41	1050	560	467
	300	750	530	460	412	364	54-4	4.5	16-41	1470	640	590
	350	850	595	525	475	422	60-4	5	16-41	1718	700	773
	400	950	670	585	525	474	66-4	5	16-48	1885	750	1050
	500	1150	800	705	640	576	70-4	5	20-54	2410	850	1775
	600	1350	930	820	750	678	76-5	6	20-58	2895	1000	2960

# HIGH PRESSURE FLANGE CONNECTED WITH MANUAL GATE VALVE

## 高压法兰连接手动闸阀

Z41<sup>W</sup><sub>Y</sub> - <sup>100</sup>/<sub>160</sub> C、I、P、R

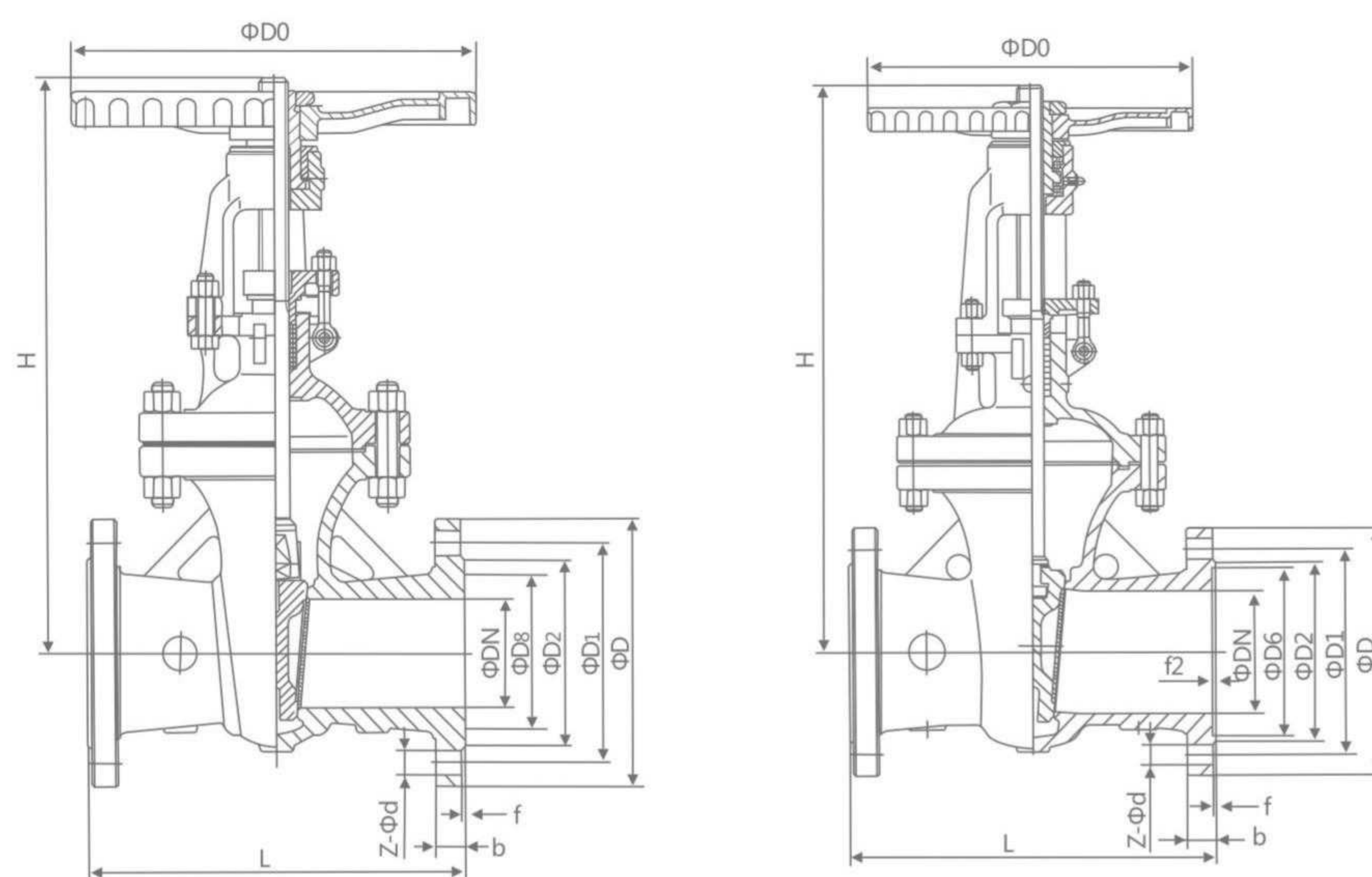

JB/T79.2-1994

JB/T79.4-1994

主要外形尺寸及连接尺寸 Main external and connection dimension

公称压力 PN(MPa)	公称通径 DN(mm)	尺寸 Size(mm)										重量 Weight (kg)
		L	D	D1	D2	D8	D6	b	Z-φd	H	D0	
10.0	15	170	105	75	55	35	40	20	4-14	140	120	6.5
	20	190	125	90	68	45	51	22	4-18	140	120	9
	25	210	135	100	78	50	58	24	4-18	310	200	13
	32	230	150	110	82	65	66	24	4-23	320	220	20
	40	240	165	125	95	75	76	26	4-23	360	240	60
	50	250	195	145	112	85	88	28	4-25	490	360	50
	65	280	220	170	138	110	110	32	8-25	540	400	70
	80	310	230	180	148	115	121	34	8-25	572	400	100
	100	350	265	210	172	145	150	38	8-30	573	400	110
	125	400	310	250	210	175	176	42	8-34	744	560	180
	150	450	350	290	250	205	204	46	12-34	800	560	250
	200	550	430	360	312	265	260	54	12-41	800	560	360
	250	650	500	430	382	320	313	60	12-41	1050	640	560
	300	750	585	500	442	375	364	70	16-48	1200	720	795
	350	850	655	560	498	420	422	76	16-54	1430	800	1155
	400	950	715	620	558	480	474	80	16-54	1743	850	1370
500	1150	815	724	635	584	576	89	24-54	2055	900	1785	
16.0	15	170	110	75	52	35	40	24	4-18	230	200	7
	20	190	130	90	62	45	51	26	4-23	260	200	10
	25	210	140	100	72	50	58	28	4-23	280	280	14
	32	230	165	115	85	65	66	30	4-25	312	320	21
	40	260	175	125	92	75	76	32	4-27	350	320	26
	50	300	215	165	132	95	88	36	8-25	512	360	73
	65	340	245	190	152	110	110	44	8-30	560	360	110
	80	390	260	205	168	130	121	46	8-30	585	400	141
	100	450	300	240	200	160	150	48	8-34	631	450	185
	125	525	355	285	238	190	176	60	8-41	723	560	320
	150	600	390	318	270	205	204	66	12-41	820	640	462
	200	750	480	400	345	275	260	78	12-48	990	720	711
	250	838	580	485	425	330	313	88	12-54	1120	800	1010
300	965	665	570	510	380	364	100	16-54	1300	850	1430	

Z41<sup>W</sup>-150Lb

### 一、产品概述 Product overview

法兰连接钢制闸阀适用于ANSI Class150 ~ 900、PN2.0 ~ 16.0MPa、JIS10 ~ 20K，工作温度-29 ~ 425℃（碳钢）及-40 ~ 500℃（不锈钢）的各种管路上，用于截断或接通管路中的介质。通过选用不同的材质，可适用于水、蒸汽、油品、硝酸、醋酸、强氧化性介质及尿素等多种介质。有手动、伞齿轮传动及电动等。

### 二、结构特点 Structural characteristics of

- 1、产品设计制造符合国外先进标准要求，密封可靠，性能优良。
- 2、结构设计紧凑合理，造型美观。
- 3、采用楔式弹性闸板结构，中大口径设置滚动轴承，启闭轻松。
- 4、阀体材料品种齐全，填料、垫片根据实际工况或用户要求合理选配，可适用于各种压力、温度及介质工况。
- 5、采用国内外多种配管法兰标准及法兰密封面型式，满足各种工程需要及用户要求

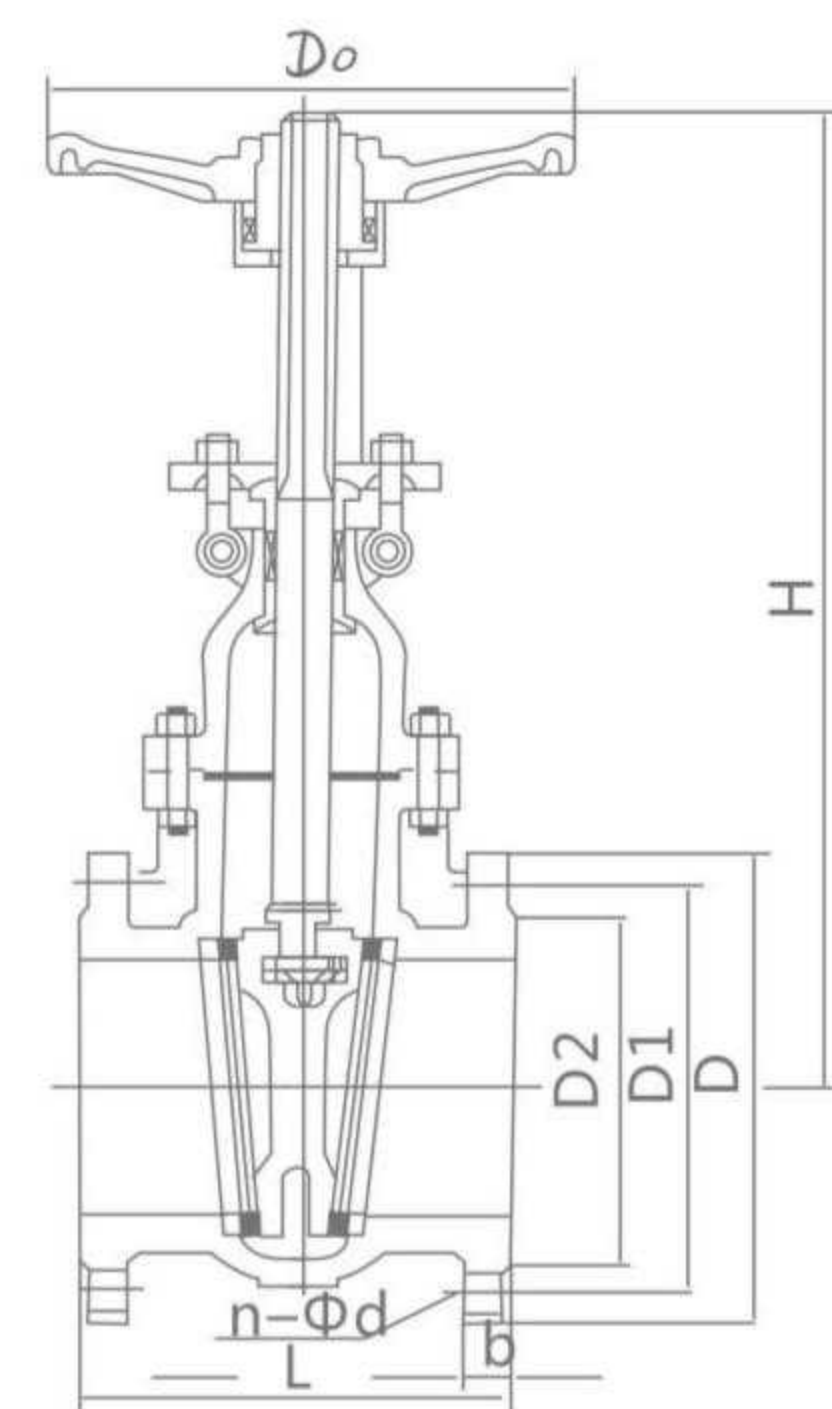

### 三、主要零件材料 Main components material

名称 Name	材料 Material								
阀体/阀盖 Body/Bonnet	CF8	CF3	CF8M	CF3M	WCB	LCB	WC6	WC9	C5
闸板 Wedge	CF8	CF3	CF8M	CF3M	WCB	LCB	WC6	WC9	C5
阀杆 Stem	F304	F304L	F316	F316L	2CR13	F304	F304	F304	F304
阀杆螺母 Stem Nut	铝青铜 Aluminium Bronze								
填料 Packing	PTFE/柔性石墨				石墨 Graphite				
垫片 Gasket	PTFE/金属缠绕垫				石墨 Graphite				
压盖 Gland	CF8	CF3	CF8M	CF3M	WCB	LCB	WC6	WC9	C5
螺栓 Bolt	不锈钢 Stainless Steel				35CrMoA				
螺母 Nut	不锈钢 Stainless Steel				45、35CrMoA				
手轮 Handwheel	铸钢 Cast Steel								

### 四、主要外形尺寸及连接尺寸 Main external and connection dimension

Class(150Lb)

规格 inch	尺寸 (mm)								
	DN	L	D	D1	D2	b	Z-Φd	H	D0
1/2"	15	108	89	60.5	35	12	4-Φ15	155	120
3/4"	20	117	98	70	43	12	4-Φ15	160	120
1"	25	127	108	79.5	51	12	4-Φ15	200	140
1 1/2"	32	140	117	89	64	13	4-Φ15	245	160
2"	40	165	127	98.5	73	15	4-Φ15	285	180
2 1/2"	50	178	152	120.5	92	16	4-Φ19	315	200
3"	65	190	178	139.5	105	18	4-Φ19	375	220
4"	80	203	190	152.5	127	19	4-Φ19	400	240
5"	100	229	229	190.5	157	24	8-Φ19	460	280
6"	125	254	254	216	186	24	8-Φ22	540	300
8"	150	267	279	241.5	216	26	8-Φ22	620	320
10"	200	292	343	298.5	270	29	8-Φ22	800	400
12"	250	330	406	362	324	31	12-Φ25	850	450
14"	300	356	483	432	381	32	12-Φ25	1000	500
16"	350	381	533	476	413	35	12-Φ29	1300	600
18"	400	406	597	540	470	37	16-Φ29	1400	600
20"	450	432	635	578	533	40	16-Φ32	1600	650
24"	500	457	398	635	584	43	20-Φ32	1850	650
24"	600	508	813	749.5	692	48	20-Φ35	2200	700

# API GATE VALVES

## 美标闸阀

Class(300Lb)

规格 inch	尺寸(mm)								
	DN	L	D	D1	D2	B	Z-Φd	H	H
1/2"	15	140	95	66.5	35	15	4-Φ15	155	120
3/4"	20	152	117	82.5	43	16	4-Φ19	160	120
1"	25	165	124	89	51	18	4-Φ19	200	140
1 1/4"	32	178	133	98.5	64	19	4-Φ19	250	160
1 1/2"	40	190	156	114.5	73	21	4-Φ22	290	180
2"	50	216	165	127	92	22	8-Φ19	330	200
2"	65	241	190	149	105	25	8-Φ22	385	220
3"	80	283	210	168.5	127	29	8-Φ22	410	240
4"	100	305	254	200	157	32	8-Φ22	480	280
5"	125	381	279	235	186	35	8-Φ22	630	300
6"	150	403	318	270	216	37	12-Φ22	690	320
8"	200	419	381	330	270	41	12-Φ25	830	400
10"	250	457	445	387.5	324	48	16-Φ29	1003	450
12"	300	502	521	451	381	51	16-Φ32	1137	500
14"	350	762	584	514.5	413	54	20-Φ32	1489	600
16"	400	838	648	571.5	470	57	20-Φ35	1581	600
18"	450	914	711	628.5	533	60	24-Φ35	2017	650
20"	500	991	775	686	584	64	24-Φ35	2228	650
24"	600	1143	914	813	692	70	24-Φ41	2650	700

Class(600Lb)

规格 inch	尺寸(mm)								
	DN	L	D	D1	D2	B	Z-Φd	H	H
1/2"	15	165	95	66.5	35	15	4-Φ15	155	155
3/4"	20	190	118	82.5	43	16	4-Φ19	160	160
1"	25	216	124	89	51	18	4-Φ19	200	200
1 1/4"	32	229	133	98.5	64	21	4-Φ19	250	250
1 1/2"	40	241	156	114.5	73	23	4-Φ22	290	290
2"	50	292	165	127	92	26	8-Φ19	350	350
2?"	65	330	190	149	105	29	8-Φ22	430	430
3"	80	356	210	168	127	32	8-Φ22	470	470
4"	100	432	273	216	157	38	8-Φ25	570	570
5"	125	508	330	266.5	186	45	8-Φ29	700	700
6"	150	559	356	292	216	48	12-Φ29	750	750
8"	200	660	419	349	270	56	12-Φ32	830	830
10"	250	787	508	432	324	64	16-Φ35	1210	1210
12"	300	838	559	489	381	67	20-Φ35	1350	1350
14"	350	889	603	527	413	70	20-Φ38	1600	1600
16"	400	991	686	603	470	77	20-Φ41	1800	1800
18"	450	1092	743	654	533	83	20-Φ44	2110	2110
20"	500	1194	813	724	584	89	24-Φ22	2350	2350
24"	600	1397	940	838	692	102	24-Φ52	2900	2900

# JIS GATE VALVE

## 日标闸阀

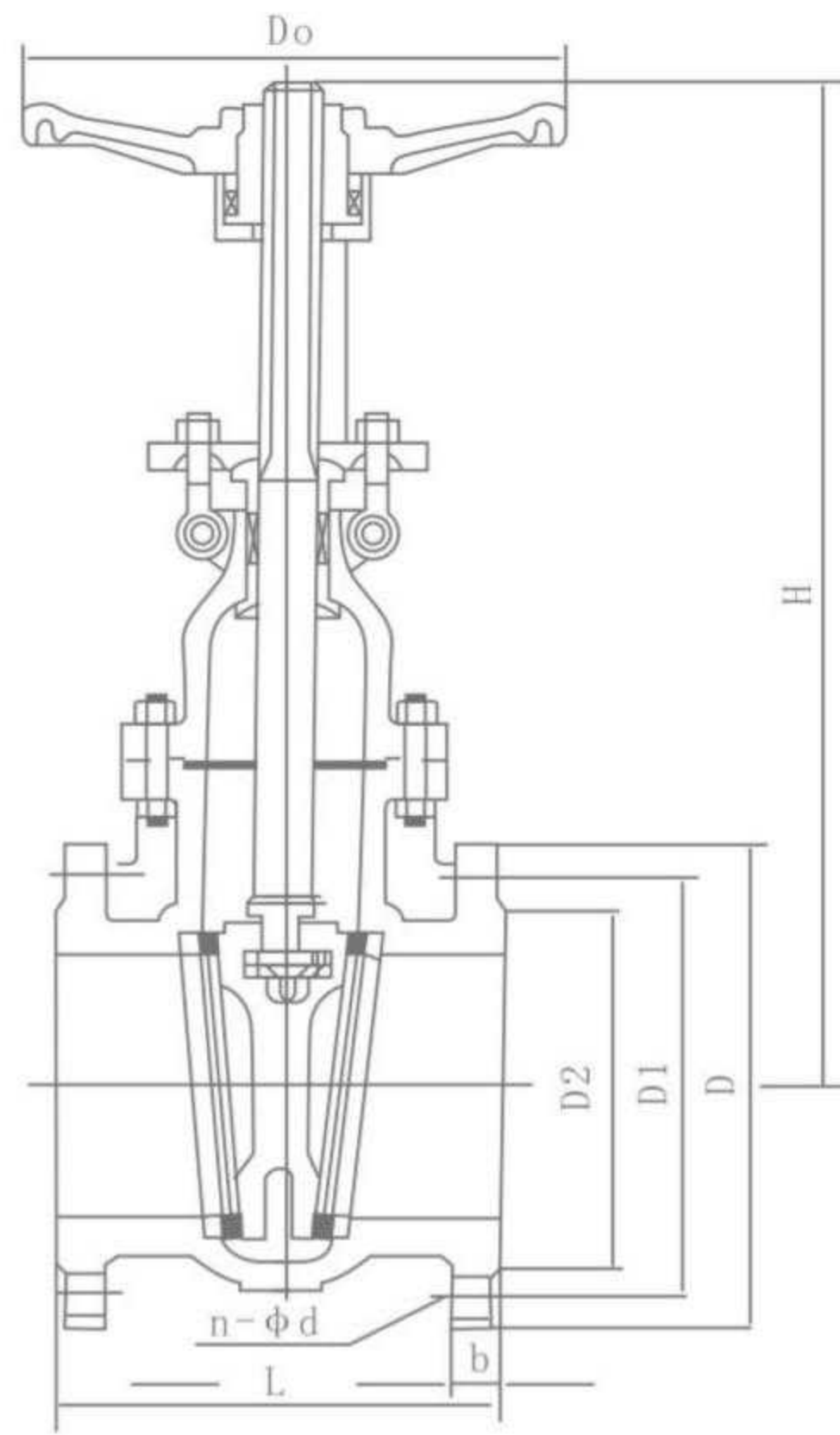

### 执行标准 Execution standard

设计与制造 Design and Manufacture	结构长度 Structure Length	连接法兰 Connection flange	压力-温度等级 Pressure-temperature rating	试验-检验 Test and Inspection
JIS B2073 B2083	JIS B2002	JIS B2212 B2214	JIS B2073 B2083	JIS B2003

### 规格主要尺寸 Main size

DN		10K		
mm	in	L	H	D0
50	2	178	409	200
65	2½	190	535	250
80	3	203	570	250
100	4	229	590	250
150	6	267	630	300
200	8	292	960	350
250	10	330	1158	400
300	12	356	1378	450
350	14	381	1543	500
400	16	406	1738	600
450	18	432	1959	600
500	20	457	2214	680
		20K		
50	2	216	480	200
65	2½	241	510	250
80	3	283	580	280
100	4	305	700	350
150	6	403	940	400
200	8	419	1190	450
250	10	457	1390	500
300	12	502	1600	500
350	14	762	1750	600
400	16	838	1900	600
450	18	914	2320	650

# SLURRY KNIFE GATE VALVE SHAPE DESCRIPTION

## 刀形浆闸阀说明

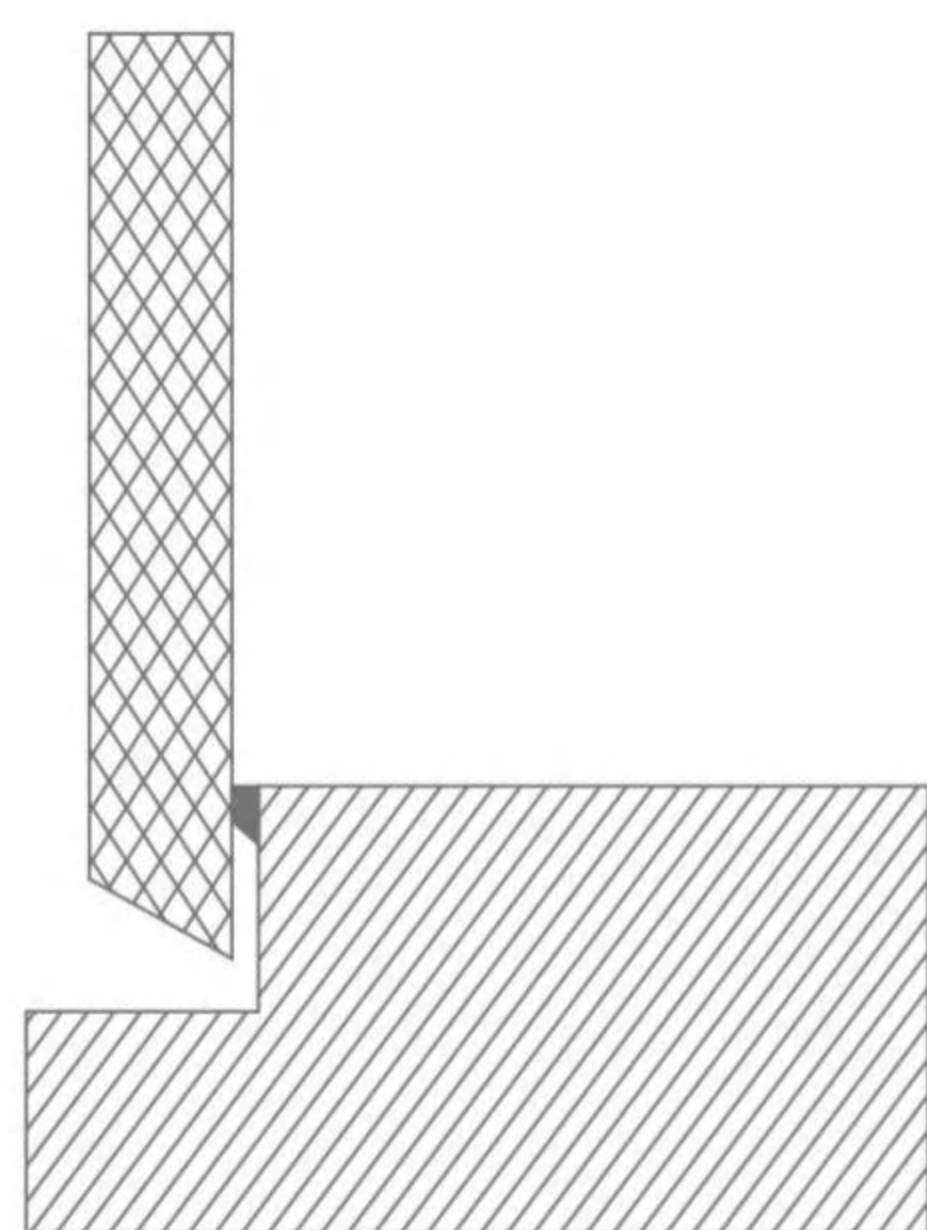

硬密封 Hard seal

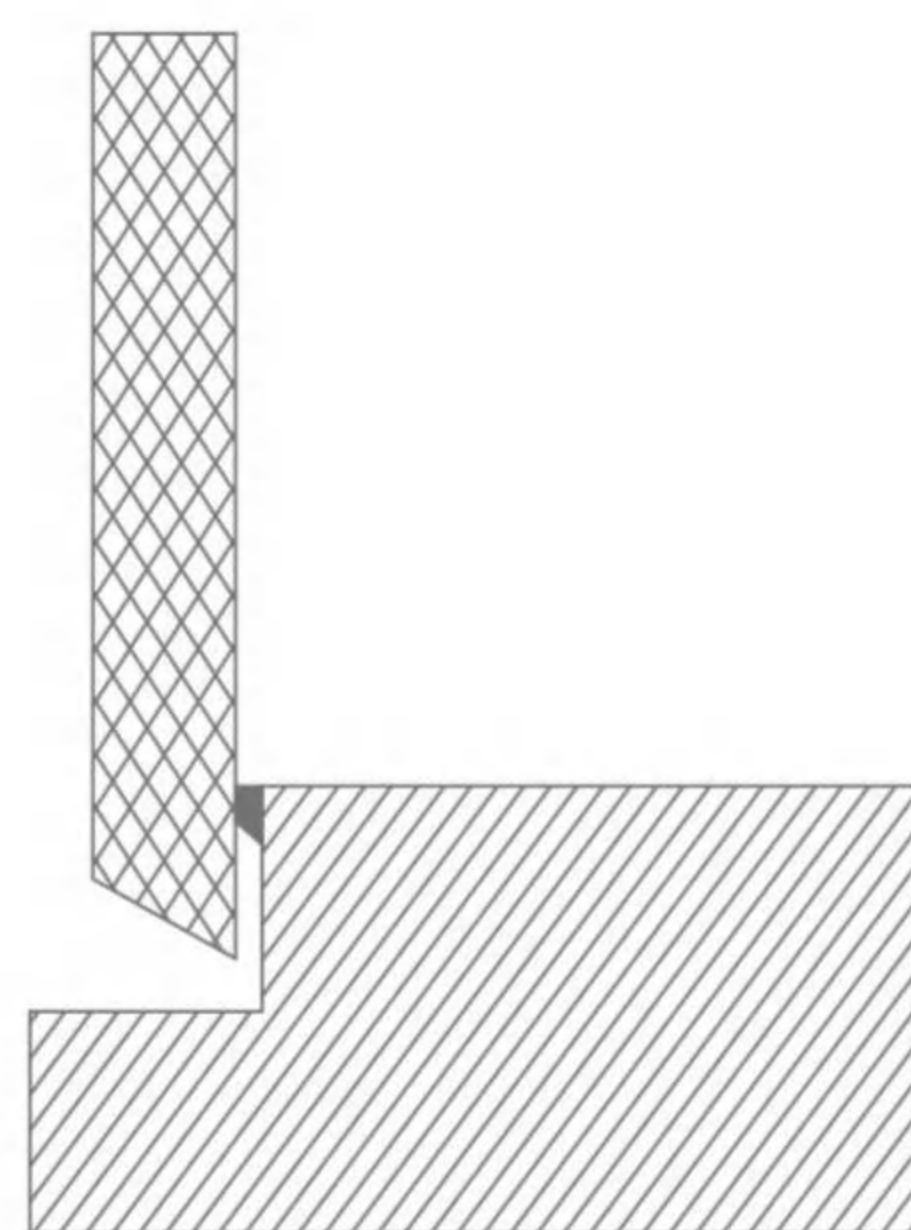

软密封 Soft seal

### 产品概述 Product overview

1、刀形浆闸阀按照口径不同制成暗杆和明杆两种形式（暗杆DN200~900mm,明杆DN50~900mm），全圆形的直流通道设计不存渣、不卡阻。刀板底端加工成刀刃状，对松软物料如纤维、纸浆、木浆具有切断功能，同时有良好开启和关闭作用。在刀板上端安装有硬聚四氟乙烯刮泥器，可防止粉尘、砂砾等擦伤性物质进入填料盒，可显著提高刀板寿命。阀板材质选用不锈钢、精磨抛光处理可获得最佳密封效果。

2、阀体、填料涵为精密铸造，其中阀体采用凸缘式整体铸造，不锈钢、硬质合金材质可根据用户需要选用304、316、316L、WCB、2Cr13,密封圈采用PTFE增强聚四氟乙烯材质，耐腐蚀、耐磨损、不沾渣。

3、阀板有5个支撑点，使阀板有很好的自对中。当阀门处于关闭状态，并承受背压时，阀板不发生偏移。

4、刀形浆闸阀可以配置手轮、手动拉链、正齿轮传动、伞齿轮传动、气动和电动。

5、刀形浆闸阀内部可制成V形、三角形、五角形通道，以适应流体调节控制要求。

6、刀形浆闸阀连接形式有对夹式、法兰支耳式，密封有金属对金属硬密封、金属对聚胺脂、带增强的聚四氟乙烯；软密封。

1,Slurry knife gate valve in accordance with the caliber of different-shaped dark bar and the next shot is made in two forms (dark bar DN200 ~ 900mm, clear shot DN50 ~ 900mm), full circle design of the DC channel residue does not exist, no jamming. Knife blade-like plate at the bottom of processed, on soft materials such as fiber, pulp, wood pulp has a cutting function, while the role of a good opening and closing. Knife board installed in the top of the hard Teflon scraper device, to prevent dust, sand and other substances into the packing box scratch can significantly increase the life of blades. Valve plate material selection of stainless steel, grinding polished for best sealing effect.

2, Valve, filling culvert for the precision casting, in which the whole body with flange-type casting, stainless steel, hard alloy material can be selected according to user needs 304,316,316 L, WCB, 2Cr13, enhanced PTFE seals with PTFE vinyl material, corrosion, wear, do not stick residue.

3, Valve plate has five support points,so a very good disc from the middle.When the valve is at the off-position,when and withstands the back pressure,the valve board does not have the displacement.

4, Slurry knife gate valve can be configured to hand-shaped wheel, manual zipper, spur gear drive, bevel gear, pneumatic and electric.

5, Knife gate slurry form can be made within the V-shaped, triangular, pentagonal channels to meet the requirements of fluid regulation and control.

6, Knife-shaped connection in the form of slurry valve wafer type, flange supporting ear, sealed with metal on metal seal, metal on polyurethane, with enhanced PTFE; soft seal.

工作温度：软密封（PTFE）：-40℃~230℃

碳素钢：-29℃~425℃

不锈钢：-40℃~600℃

铬钼钒钢：≤550℃

工作压力：0.6、1.0、1.6MPa

执行标准：设计按JB/T8691-1998

法兰按GB/T9113.1-2000

结构长度按GB/T15188.2-94

试验和验收按GB/T13927

Working temperature: Soft Seal (PTFE): -40℃~230℃

Carbon steel: -29℃~425℃

Stainless steel: -40℃~600℃

Chrome molybdenum Vanadium Steel: ≤550℃

Working pressure: 0.6, 1.0, 1.6 MPa

Executive standard: Design by JB/T8691-1998

Flange by GB/T9113.1-2000

Structural length according to GB/T15188.2-94

Test and acceptance by GB/T13927

### 适用介质Applicable medium

金矿粉、尾矿、纸浆、木浆、纤维、粉尘、化学品处理污水、沉淀池、矿砂、炉渣、煤泥、沥青、料仓出口、水果、谷物、水泥浆、屠宰厂废水、气动输送管线或啤酒酿制的介质。

Gold powder, tailings, pulp, wood pulp, fibers, dust, chemicals, sewage treatment, settling ponds, ore, slag, slime, asphalt, bunker exit, fruits, grains, cement, slaughter house wastewater, air transport pipeline or beer brewed in the media.

### 产品特点Product characteristic

设计紧凑、占据空间小、重量轻、价格便宜、易于安装、耐磨防堵措施完善、便于维修、使用方便及寿命长，并且可任意选用驱动装置。

Compact design, small footprint, light weight, inexpensive, easy to install, aiming to halt the measures to improve the wear resistance, easy maintenance, easy to use and long life, and can be arbitrarily selected drive.



# WAFER KNIFE DISCHARGE VALVE

PZ73<sup>X</sup><sub>F</sub>-<sup>1.0</sup><sub>1.6</sub>对夹刀形排渣阀

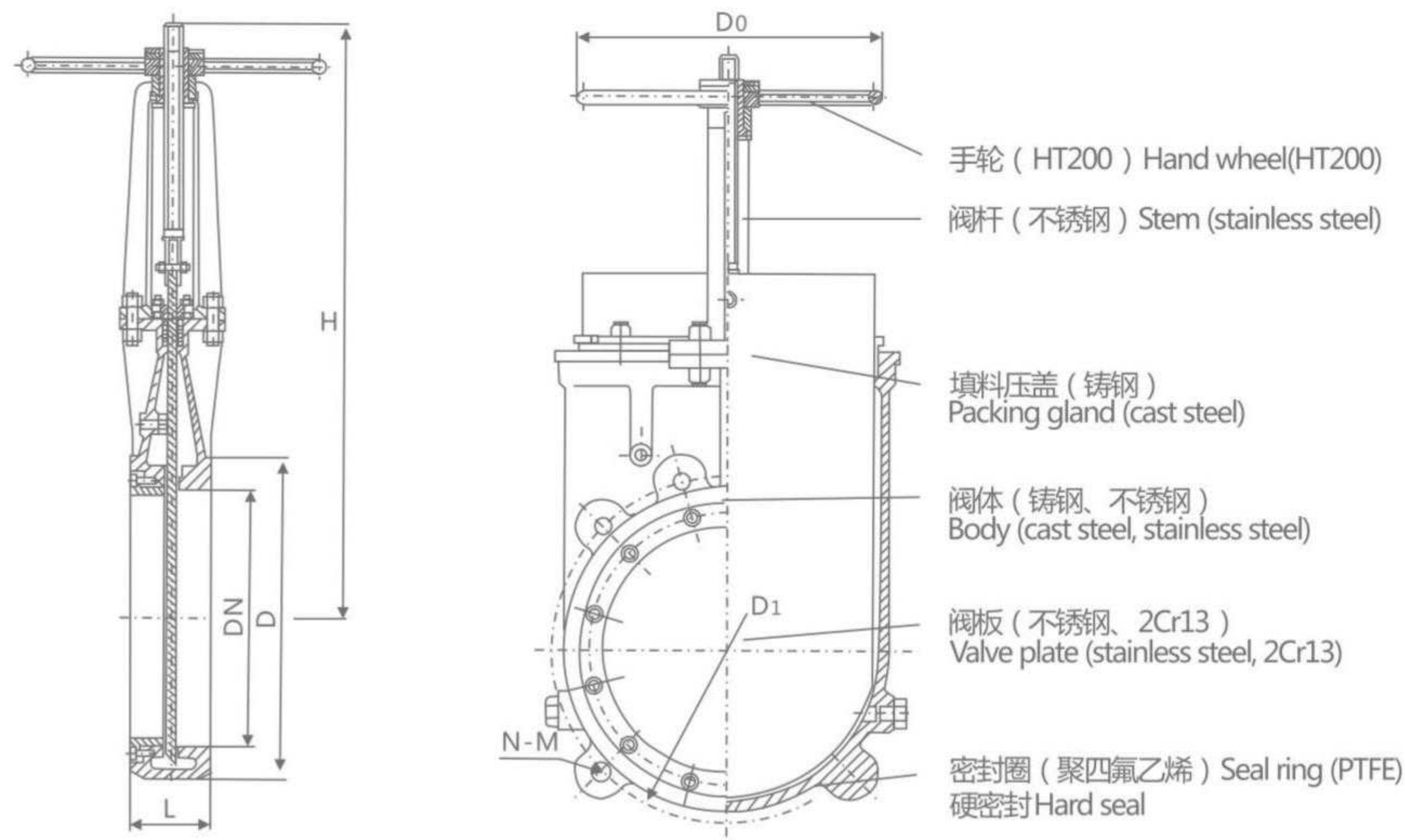

## 主要性能规范 Main Performance Specifications

公称压力 PN(MPa)	试验压力 Test pressure ( MPa )		工作温度 Working temperature ( °C )	适用介质 Applicable medium
	壳体 Case	密封 Seal		
1.0	1.5	1.1	橡胶 ≤100°C	炉渣、纸浆、污水、煤渣、灰渣、泥浆、油类 Slag, pulp, sewage, cinder, ash, mud, oil
1.6	2.4	1.8	H <sub>Y</sub> ≤425°C	

## 主要性能规范 Main Performance Specifications

体、盖 Body, cover	闸板 Gate	阀杆 Stem	密封面 Sealing surface
不锈钢、碳钢、灰铸铁 Stainless steel, carbon steel, gray cast iron	碳钢、不锈钢 Carbon steel, stainless steel	不锈钢 Stainless steel	橡胶、四氟、不锈钢、硬质合金 Rubber, PTFE, stainless steel, hard alloy

## 主要外形及连接尺寸 Main external and connection dimension

JB/T82.1

公称压力 PN(MPa)	公称通径 DN(mm)	尺寸 Size ( mm )						
		L	D	D1	D2	H	N-M	D0
1.0	50	60	160	125	100	300	4-M16	180
	65	60	180	145	120	320	4-M16	180
	80	70	195	160	135	340	4-M16	220
	100	71	215	180	155	390	8-M16	220
	125	71	245	210	185	430	8-M16	230
	150	80	280	240	210	510	8-M20	280
	200	80	335	295	265	580	8-M20	360
	250	94	390	350	320	680	12-M20	360
	300	98	440	400	368	840	12-M20	400
	350	100	500	460	428	950	16-M20	400
	400	110	565	515	482	1050	16-M22	400
	450	120	615	565	532	1170	20-M22	530
	500	130	670	620	585	1280	20-M22	530
	600	140	780	725	685	1490	20-M27	600

注：根据用户要求可生产全密封带防尘罩浆闸阀，主要应用于矿山、水泥、化工、食品等行业。

Note: According to user requirements to produce slurry sealed gate valve with dust cover, mainly used in mining, cement, chemical, food and other industries.

# SLURRY KNIFE GATE VALVE SHAPE DESCRIPTION

## 刀形浆闸阀说明

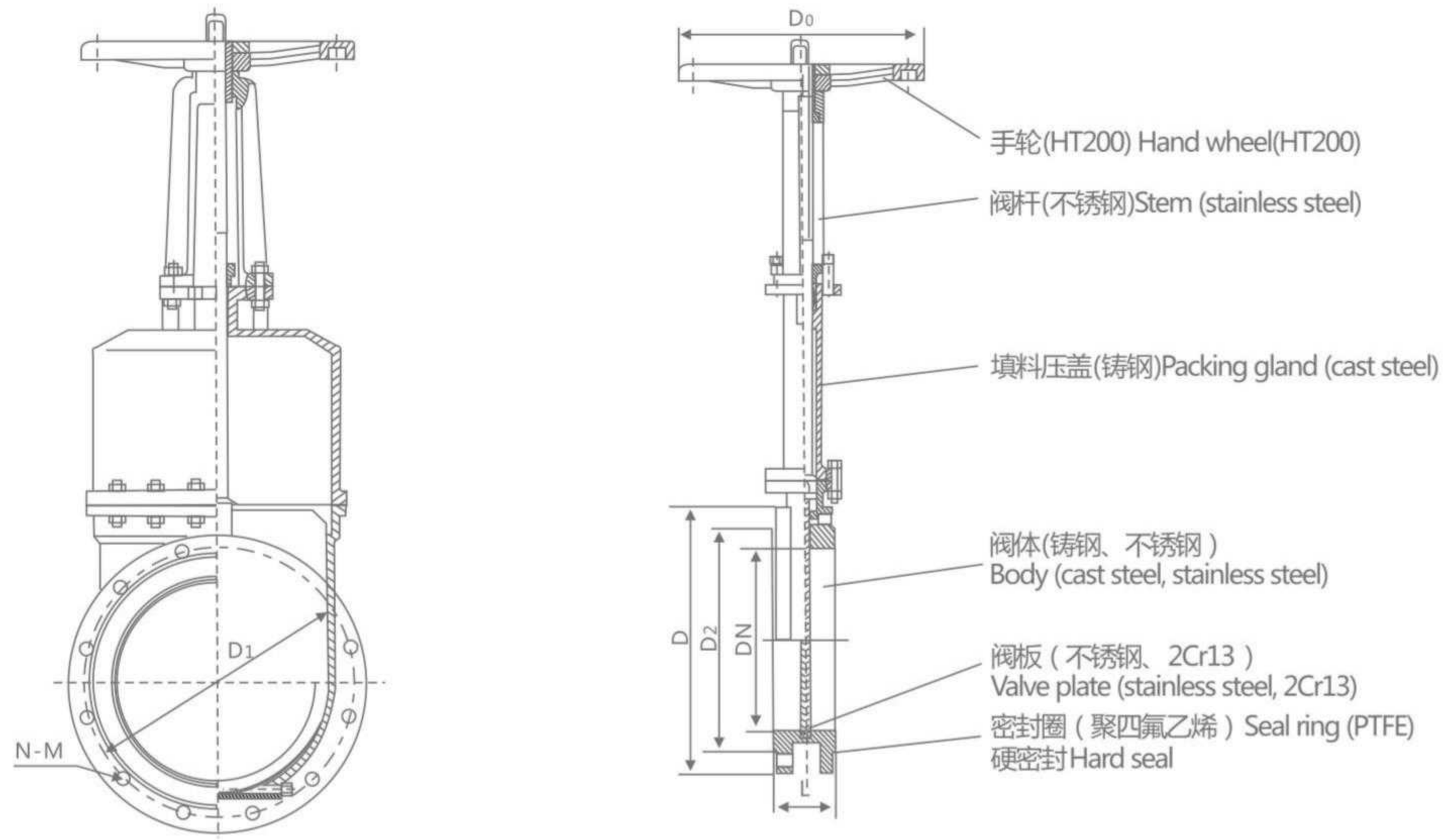

### 主要性能规范 Main Performance Specifications

公称压力 PN(MPa)	试验压力 ( MPa )		工作温度 Working temperature ( °C )	适用介质Applicable medium
	壳体Case	密封Seal		
1.0	1.5	1.1	橡胶 ≤ 80°C	炉渣、纸浆、污水、煤渣、灰渣、泥浆、油类 Slag, pulp, sewage, cinder, ash, mud, oil
1.6	2.4	1.8	H <sub>y</sub> ≤ 425°C	

### 主要性能规范 Main Performance Specifications

体、盖Body, cover	闸板Gate	阀杆Stem	密封面Sealing surface
不锈钢、碳钢、灰铸铁 Stainless steel, carbon steel, gray cast iron	碳钢、不锈钢 Carbon steel, stainless steel	不锈钢 Stainless steel	橡胶、四氟、不锈钢、硬质合金 Rubber, PTFE, stainless steel, hard alloy

### 主要外形及连接尺寸 Main external and connection dimension

JB/T82.1

公称压力 PN(MPa)	公称通径 DN(mm)	尺寸Size ( mm )							重量 ( Kg )
		L	D	D1	D2	H	N-M	D0	
1.0	150	70	280	240	210	580	8-M23	280	
	200	80	335	295	265	710	8-M23	360	
	250	85	390	350	320	800	12-M23	360	
	300	100	440	400	368	960	12-M23	400	
	350	100	500	460	428	1110	16-M23	400	
	400	110	565	515	482	1220	16-M25	400	
	450	120	615	565	532	1350	20-M25	550	
	500	130	670	620	585	1460	20-M25	550	
	600	140	780	725	685	1680	20-M30	550	
	700	165	895	840	800	1850	24-M27	600	
	800	190	1010	950	905	2180	24-M30	600	
900	200	1110	1050	1005	2280	28-M30	600		

# MING BAR LUG PZ43 KNIFE GATE VALVE 明杆支耳式PZ43刀形闸阀

## 部件材质剖析说明 Component material analysis shows

代号Code	零件名称Part name	材质说明 Material quality explanation	
		名称Name	牌号Trademark
1	圆螺母Round nut	优质碳素钢Quality carbon steel	25
2	手轮Hand wheel	灰口铸铁Gray cast iron	HT200
3	轴承压盖Bearing gland	优质碳素钢Quality carbon steel	35
4	阀杆螺母Stem nut	铝青铜Aluminum bronze	ZCuAl9Mn2、ZCuAl9Fe4NiMn2
		铝黄铜Aluminum brass	ZCuZn25Al6Fe3Mn3
5	轴承Bearing	-	51110
6	阀杆Stem	不锈钢Stainless steel	304、316、2Cr13
7	支架Support	碳素钢、不锈钢 Carbon steel, stainless steel	WCB、CF8等
8	闸板Damper plate	不锈钢Stainless steel	304、316、304L、316L、2Cr13
9	螺栓螺母Bolt nut	优质碳素钢Quality carbon steel	35/25
10	填料压盖Packing cover	碳素钢Carbon Steel	WCB
11	填料Packing	柔性石墨盘根 石棉盘根 增强四氟纤维盘根 Flexible graphite packing Asbestos Packing Enhanced PTFE fiber packing	-
12	阀体Body	碳素钢、不锈钢 Carbon steel, stainless steel	WCB、CF8(304)、CF3(304L)、CF8M(316)、 CF3M(316L)、密封座堆焊合金或不锈钢 Seal surfacing alloy or stainless steel seat

# MANUAL KNIFE GATE VALVE

## Z73<sup>X</sup><sub>H</sub>-1.6 手动刀形闸阀

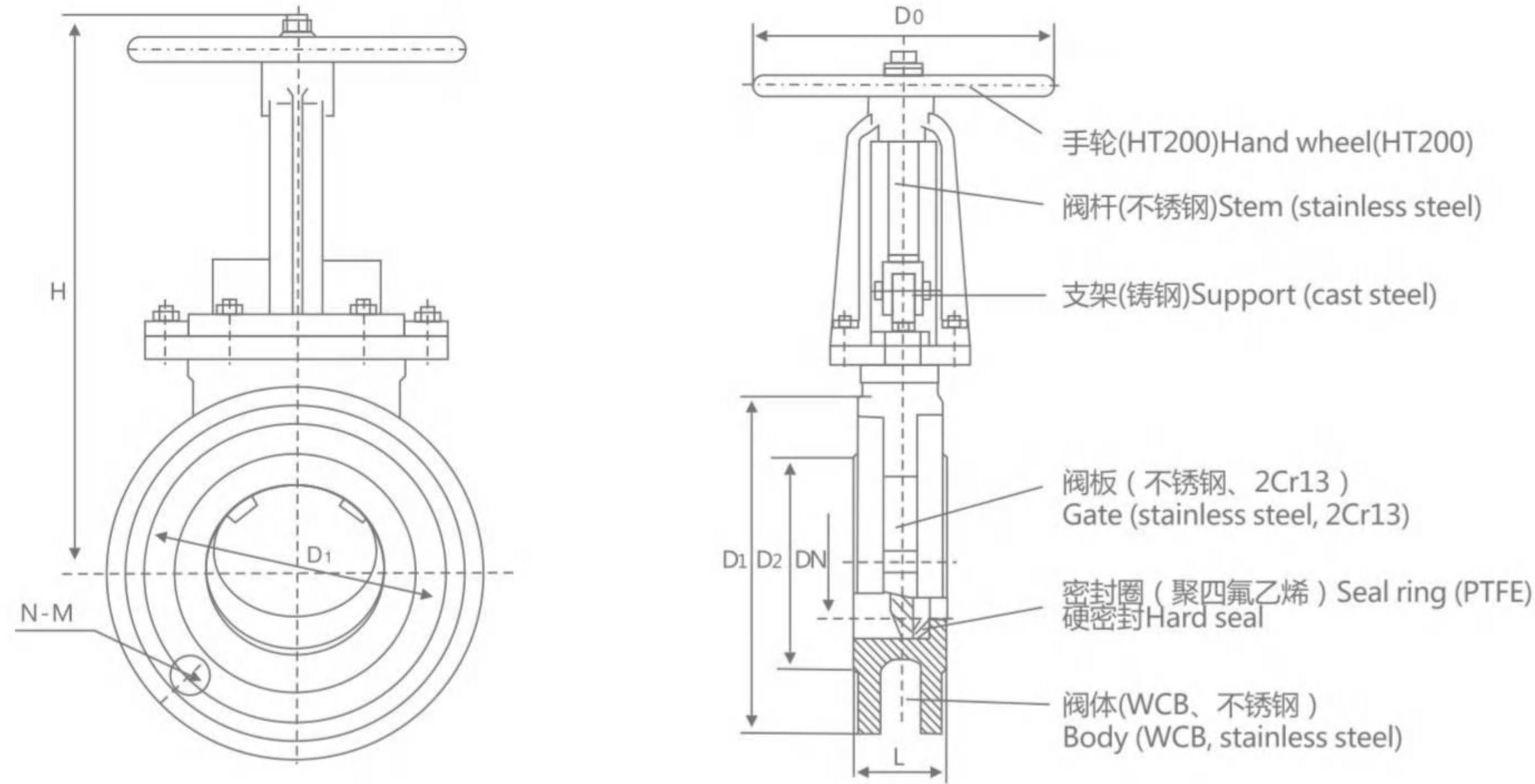

### 主要性能规范 Main Performance Specifications

公称压力 PN(MPa)	试验压力 (MPa)		工作温度 Working temperature (°C)	适用介质 Applicable medium
	壳体 Case	密封 Seal		
1.0	1.5	1.1	橡胶 ≤ 80°C	糖浆、纸浆、污水、煤浆、灰、渣水混合物 Syrup, pulp, sewage, coal slurry, ash, slag-water mixture
1.6	2.4	1.8	H <sub>y</sub> ≤ 425°C	

### 主要性能规范 Main Performance Specifications

体、盖 Body, cover	闸板 Gate	阀杆 Stem	密封面 Sealing surface
不锈钢、碳钢、灰铸铁 Stainless steel, carbon steel, gray cast iron	碳钢、不锈钢 Carbon steel, stainless steel	不锈钢 Stainless steel	橡胶、四氟、不锈钢、硬质合金 Rubber, PTFE, stainless steel, hard alloy

### 主要外形及连接尺寸 Main external and connection dimension

JB/T79.1/82.1

公称压力 PN(MPa)	公称通径 DN(mm)	尺寸 Size (mm)							重量 (Kg)
		L	D	D1	D2	H	N-M	D0	
1.0	50	50	160	125	100	285	4-M16	180	6
	65	50	180	145	120	298	4-M16	180	7
	80	50	195	160	135	315	4-M16	220	8
	100	50	215	180	155	365	8-M16	220	10
	125	50	245	210	185	400	8-M16	230	12
	150	60	280	240	210	475	8-M20	280	14
	200	60	335	295	265	540	8-M20	360	22
	250	70	390	350	320	630	12-M20	360	29
	300	80	440	400	368	780	12-M20	400	38
	350	90	500	460	428	885	16-M20	400	66
	400	100	565	515	482	990	16-M22	400	100
	450	120	615	565	532	1100	20-M22	530	119
	500	130	670	620	585	1200	20-M22	530	195
	600	140	780	725	685	1450	20-M27	600	285
	700	165	895	840	800	1700	24-M27	600	389
800	190	1010	950	905	2000	24-M30	680	529	
900	203	1110	1050	1005	2300	28-M30	680	790	
1.6	50	50	160	125	100	285	4-M16	180	6
	65	50	180	145	120	295	4-M16	180	7
	80	50	195	160	135	315	8-M16	220	8.5
	100	50	215	180	155	365	8-M16	220	10.7
	125	50	245	210	185	400	8-M16	230	13
	150	60	280	240	210	475	8-M20	280	15
	200	60	335	295	265	540	12-M20	360	23.5
	250	70	405	355	320	630	12-M22	360	31
	300	80	460	410	375	780	12-M22	400	40.7
	350	90	520	470	435	885	16-M22	400	70
	400	100	580	525	485	990	16-M27	400	107
	450	120	640	585	545	1100	20-M27	530	129
	500	130	705	650	608	1200	20-M30	530	215
	600	140	840	770	718	1450	20-M36	600	305
	700	165	910	840	788	1700	24-M36	600	410
800	190	1020	950	898	2000	24-M36	680	550	
900	203	1120	1050	998	2300	28-M36	680	820	

注：MPa1.6阀门选型按上表，法兰连接尺寸按国际，电动、正齿轮、气动阀门选型H尺寸增加气动、电动装置高度。  
Note: MPa1.6 valve selection according to the table, flange connecting dimensions according to the international, power, gear, pneumatic valve size selection of H increased air, electric plant height.

# FLAT PLATE GATE VALVE

## 平板闸阀

### 平板闸阀的主要特点 The main features of plate gate valve

- 1、本公司引进国外平板闸阀的先进技术，进行了重大的改进，其结构合理，密封可靠，维护方便。
- 2、闸板、阀座经特殊工艺处理、喷焊硬质合金，聚四氟乙烯，实现双重密封。并可注油脂辅助密封双重保护，密封更可靠，使用寿命更长。
- 3、本阀独有三重可调式填料结构，确保与阀盖、阀杆密封可靠。法兰连接尺寸按JB/T79，亦可根据客户要求指定标准生产。
- 4、有导流孔平板闸阀用于需通球清管的管线，无导流孔的平板闸阀用于不需通球清管的管线上。
- 5、阀门阀体内腔内压力升高时，阀座可自动退让泄掉过高的压力。
- 6、本阀传动机构确保阀门启闭灵活，其启闭力矩仅为普通阀门的1/3~1/2。
- 7、气动闸阀启、闭迅速，带缓冲机构，开闭无冲击，气动、手动转换结构新颖、操作灵活、方便可靠。
- 8、调节型平板闸阀适用于泵、站出口及其它需调节介质的管路上，调节和截断介质。
- 9、本阀可广泛适用于天然气、石油、化工、环保等输送管线、放空系统和油、汽储存装置上，用作启闭设备。
- 10、本公司同时还生产调节型等特殊要求的平板闸阀。
- 11、电动平板闸阀一般选用扬州电力修造厂或天津二通的电动头，也可根据用户需要选配英国罗括克Rotork(IQ)系列、德国欧玛Aul(SA系列)或由客户在国内选配任何厂家的电动头。

- 1, The company has introduced foreign advanced technology of flat gate valve and made significant improvement. Its structure is reasonable, sealing is reliable and maintenance is convenient.
- 2, Gate and seat are processed by special process and sprayed with cemented carbide and polytetrafluoroethylene to achieve double sealing. And can grease auxiliary seal double protection, seal more reliable, longer service life.
- 3, The unique triple adjustable packing structure of this valve ensures reliable sealing with bonnet and stem. Flange connection size according to JB/T79, also according to customer requirements specified standards.
- 4, The plate gate valve with orifice is used in the pipeline requiring ball pigging, and the plate gate valve without orifice is used in the pipeline not requiring ball pigging.
- 5, valve body cavity pressure rise, the valve seat can be automatically back off from too high pressure.
- 6, the valve drive mechanism to ensure that the valve open and close flexibly, the opening and closing torque is only 1/3 ~ 1/2 of the ordinary valve.
- 7, pneumatic gate valve open and close quickly, with buffer mechanism, open and close without impact, pneumatic, manual conversion structure, flexible, convenient and reliable.
- 8, regulating type flat gate valve is suitable for pump, station outlet and other need to adjust the medium of the pipeline, regulation and cut off the medium.
- 9, the valve can be widely used in natural gas, petroleum, chemical, environmental protection and other transmission pipelines, vent system and oil, gas storage device, as a device for opening and closing.
- 10, The company also produces flat gate valves for regulating and other special requirements.
- 11, electric plate gate valve generally choose yangzhou electric power repair factory or tianjin ertong electric head, also according to the needs of users with Rotork(IQ) series, Germany omar Aul(SA series) or by customers in the domestic selection of any manufacturers electric head.

### 主要零件材料 Main parts material

零件名称 Part name	材料Material			
阀体阀盖Body cover	WCB	I	CF8、CF8MCF3、CF3M	抗硫WCB
闸板Gate	不锈钢板、合金板(表面经特殊处理过或焊接硬质合金) Stainless steel plate, alloy plate (a special treated surface or welding carbide)	40Cr(密封面焊硬质合金) Welding carbide seal surface)	304L、316L	WCB+STL
阀座(密封面) Seat (sealing surface)	橡胶、氟塑料、不锈钢、渗氮钢、硬质合金Rubber, fluorine plastic, stainless steel, nitrating steel cemented carbide			
阀杆Stem	不锈钢Stainless steel	318钢Steel	318钢Steel	318钢Steel
阀杆螺母Stem nut	铝青铜Aluminum bronze			
填料Packing	膨胀石墨Expanded Graphite	增强氟塑Enhance the fluorine	聚四氟乙烯PTFE	F4、氟橡胶 Fluorine rubber
O形密封圈O-ring	丁腈橡胶NBR	丁腈橡胶NBR	氟橡胶Fluorine rubber	氟橡胶 Fluorine rubber

### 性能规范和压力试验 Performance specifications and pressure test

压力等级 Pressure rating	常温下试验压力Under normal temperature test pressure(MPa)				工作压力 Working pressure (MPa)	适用温度 Applicable temperature (°C)	适用介质Applicable medium	
	液体密封 Fluid sealing	气体密封 Gas seals	液体壳体 Fluid sealing	低压密封 Low pressure seal			抗硫型 Anti-sulfur	基本型 Basic
公称压力 (MPa)	1.6	1.76	1.76	2.4	气体gas 0.5 ~ 0.7	通用型 Universal -29 ~ 121	含H2S和Co2 ≤ 800mg/Nm³介质	非腐蚀性 石油、天 然气、水等 Non-corrosive oil, gas, water, etc.
	2.5	2.75	2.75	2.75				
	4.0	4.4	4.4	6				
	6.4	7.04	7.04	9.6				
	10.0	11	11	15				
	16.0	17.6	17.6	24				
磅级 Pound class (Lb)	25.0	27.5	27.5	37.5	D型 -46 ~ 121	G型 -29 ~ 250		
	150	2.3	2.3	3.1				
	300	5.52	5.52	7.58				
	400	7.31	7.31	10.0				
	600	11.03	11.03	15.0				
900	16.54	16.54	22.4	15.19				

# FLAT PLATE GATE VALVE

## 平板闸阀

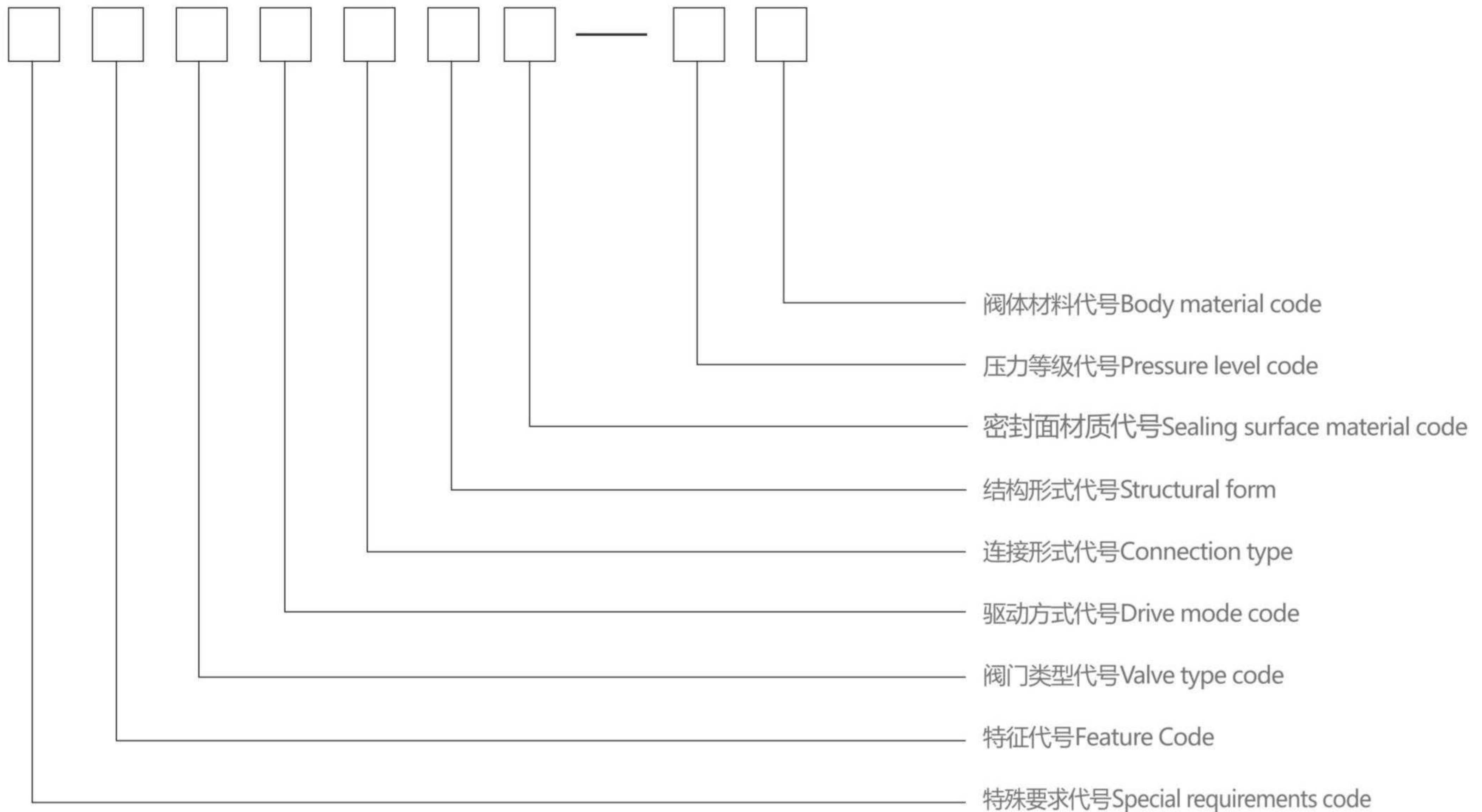

特殊要求代号：K抗硫型 Special request code: K- anti-sulfur

特征代号：W无导流孔 D带导流孔 G高压型 ZB自动补偿

Feature Code: W- Without bank guiding hole D- With bank guiding hole G- High pressure ZB- Automatic compensation

阀门类型代号：PZ平板闸阀

Valve Type Code: PZ-plate gate valve

驱动方式代号：手轮传动省略 5伞齿轮传动 6气动 9电动（手动传动略）

Drive mode code: Hand wheel drive omitted 5- Bevel gear 6- Pneumatic 9- Electric (manual transmission abbreviated)

连接形式代号：4法兰连接 6对焊连接 7对夹连接 8卡箍

Connection Type code: 4 - Flange connection) 6- Welded connection 7- On the wafer 8- Clamp

结构形式代号：3明杆平行式单闸板 4明杆平板式双闸板

Structural form: 3 - Ming bar parallel single gate 4- Rising stem slab double plate

密封面材质代号：Y硬质合金 H合金钢 D渗氮钢 F增强聚四氟乙烯 X橡胶 W阀体直接加工

Sealing surface material code: Y-carbide H-alloy steel D-nitride steel F-PTFE X-Rubber W-Body direct process

压力等级代号：公称压力MPa的10倍、磅级为实数

Pressure rating code: Nominal pressure MPa 10 times, pound class is a real number

阀体材料代号：C-WCB(PN≥2.5MPa可省略) I-WC6、ZG1Cr5Mo V-WC9、ZG20CrMoV P-CF8、ZG1Cr18Ni9Ti

Body Material Code: C-WCB (PN ≥ 2.5MPa can be omitted)

R-CF8M、ZG1Cr18Ni12Mo2Ti S-CF3 L-CF3M F-LCB N-LC3

例1：WPZ544Y-16C

表示公称压力为1.6MPa、伞齿轮传动、法兰连接、无导流孔、明杆平行式双闸板平板闸阀，阀体材料为WCB,密封面材料为硬质合金。  
Said nominal pressure 1.6MPa, bevel gear, flange connection, without diversion hole, outshot Parallel Double plate gate valve, valve body material WCB, sealing surface material is cemented carbide.

例2:DPZ943Y-150P

表示压力等级为Class 150、电动、法兰连接、有导流孔、明杆平行式单闸板平板闸阀，阀体材料为CF8,密封面材质合金。  
The pressure rating of Class 150, Electric, flange connection, a deflector, clear single-pole parallel plate gate valve, the valve body material is Cf8, sealing surface material alloy.

# FLAT PLATE GATE VALVE WITHOUT DIVERSION HOLE

## 无导流孔平板闸阀

### 手动导流孔平板闸阀

Manual flat gate valve without bank guiding hole

型号 model : (K)WPZ43F、(K)WPZ44F

PN1.6 ~ 10.0MPa

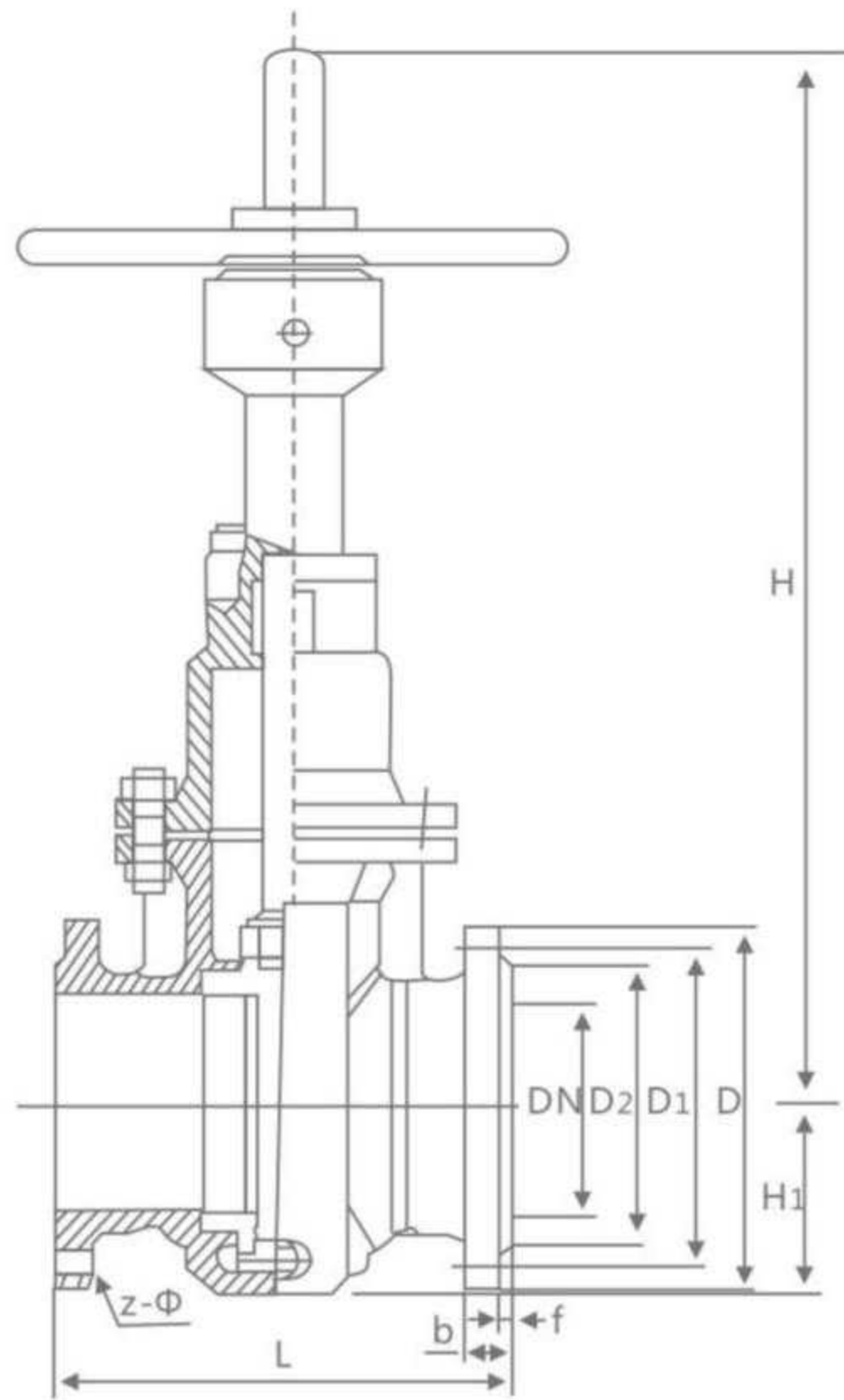

### 电动无导流孔平板闸阀

Electric flat gate valve without bank guiding hole

型号 model : (K)WPZ943F、(K)WPZ944F

PN1.6 ~ 10.0MPa

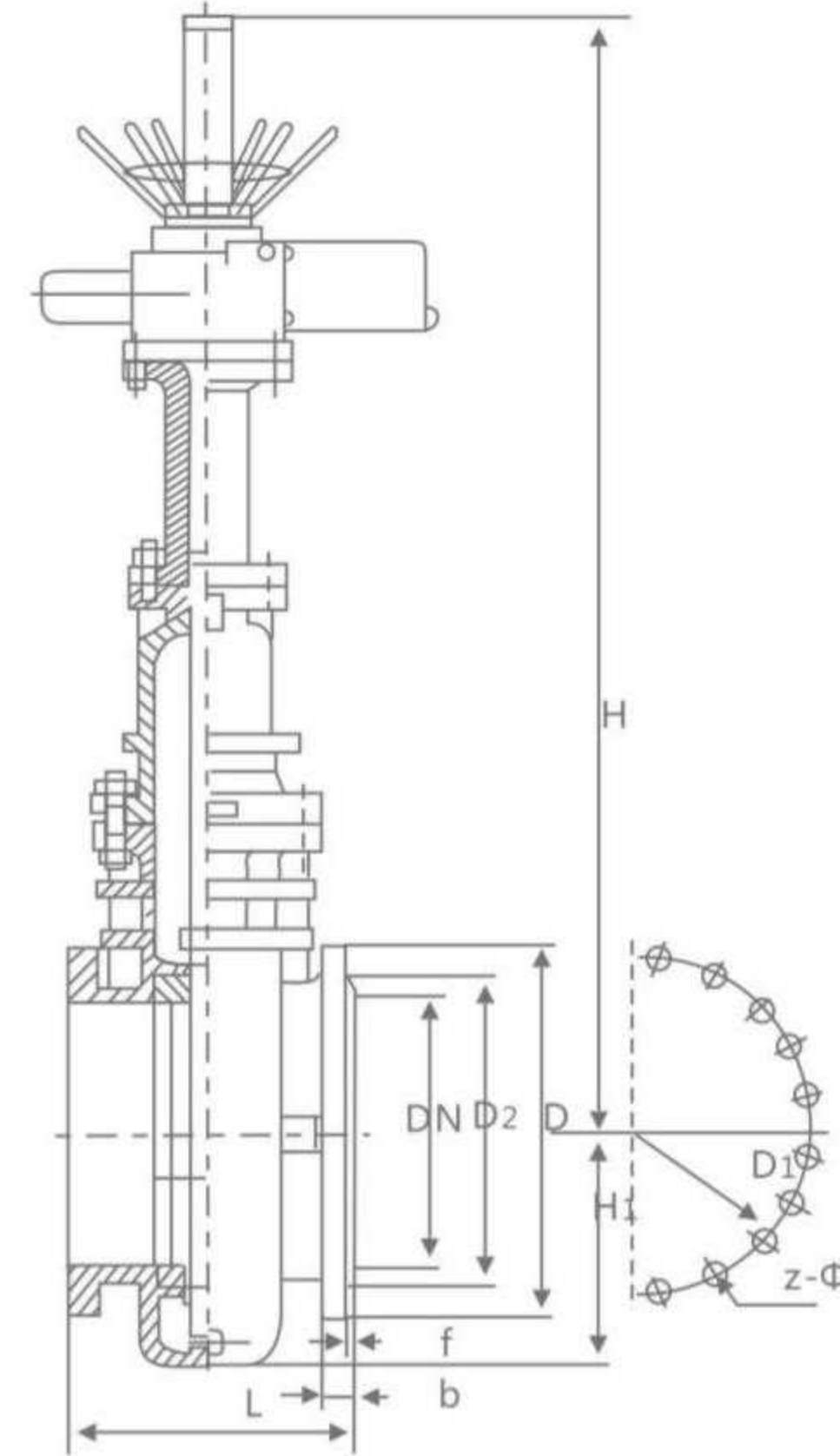

### 锥齿轮传动无导流孔平板闸阀

Bevel gear transmission flat gate valve without bank guiding hole

型号 model : (K)WPZ543F、(K)WPZ544F

PN1.6 ~ 10.0MPa

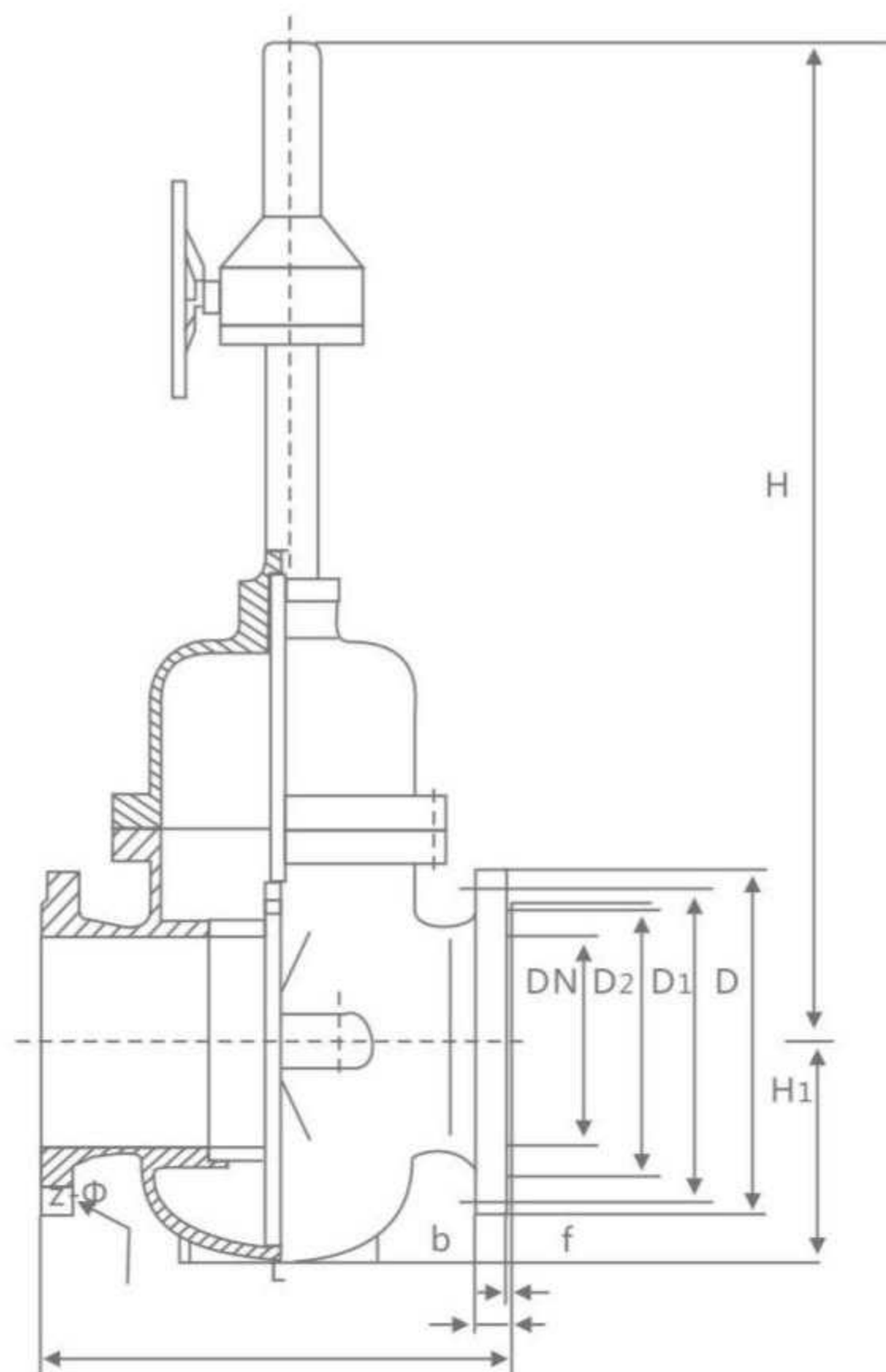

### 气动无导流孔平板闸阀

Pneumatic flat gate valve without bank guiding hole

型号 model : (K)WPZ643F、(K)WPZ644F

PN1.6 ~ 10.0MPa

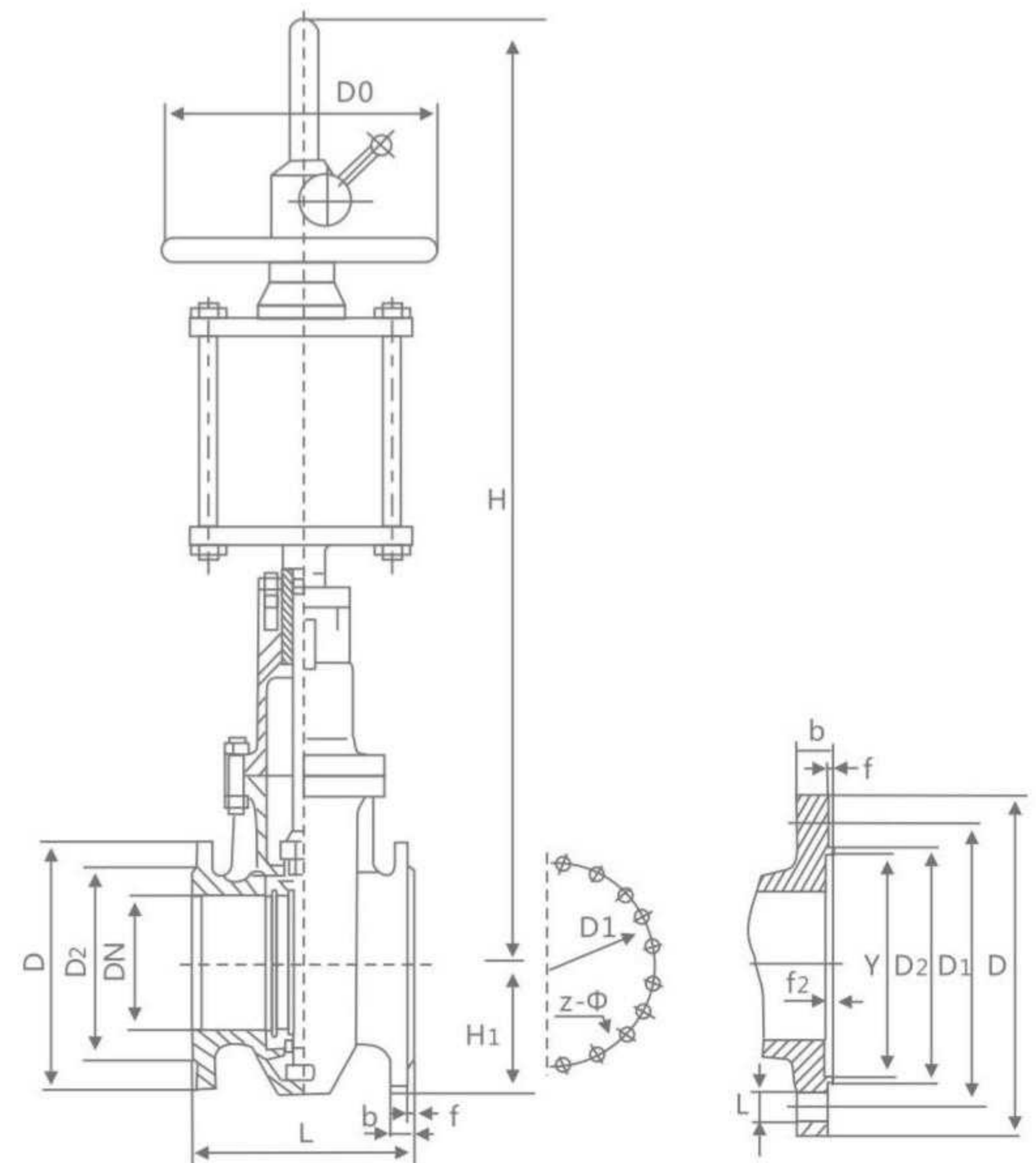

# FLAT PLATE GATE VALVE WITHOUT DIVERSION HOLE

## 无导流孔平板闸阀

主要外形尺寸及连接尺寸 Main external and connection dimension ( JB/T79.1-1994 )

公称压力 PN(MPa)	公称通径 DN(mm)	尺寸Size ( mm )									
		L	D	D1	D2	D0	f	b	H	H1	z-Φ
1.6	50	178	160	125	100	250	3	16	584	80	4-18
	65	190	180	145	120	250	3	18	634	95	4-18
	80	203	195	160	135	250	3	20	688	100	8-18
	100	229	215	180	155	300	3	20	863	114	8-18
	125	254	245	210	185	350	3	22	940	132	8-18
	150	267	280	240	210	350	3	24	1030	150	8-23
	200	292	335	295	265	350	3	26	1277	168	12-23
	250	330	405	355	320	400	3	30	1491	203	12-25
	300	356	460	410	375	450	4	30	1701	237	12-25
	350	381	520	470	435	500	4	34	1875	265	16-25
	400	406	580	525	485	305	4	36	2180	300	16-30
	450	432	640	585	545	305	4	40	2440	325	20-30
	500	457	705	650	608	305	4	44	2860	360	20-34
	600	508	840	770	718	305	5	48	3450	425	20-41
	700	610	910	840	788	305	5	50	3960	460	24-41
	800	660	1020	950	898	305	5	52	4550	512	24-41
900	711	1120	1050	998		5	54	5250	565	28-41	
1000	811	1255	1170	1110		5	56	5870	630	28-48	
2.5	50	178	160	125	100	250	3	20	584	80	4-18
	65	190	180	145	120	250	3	22	634	95	8-18
	80	203	195	160	135	250	3	22	688	100	8-18
	100	229	230	190	160	300	3	24	863	114	8-23
	125	254	270	220	188	350	3	28	940	132	8-25
	150	267	300	250	218	350	3	30	1030	150	8-25
	200	292	360	310	278	350	3	34	1277	168	12-25
	250	330	425	370	332	400	3	36	1491	203	12-30
	300	356	485	430	390	450	4	40	1701	237	16-30
	350	381	550	490	448	500	4	44	1875	265	16-34
	400	406	610	550	505	305	4	48	2180	300	16-34
	450	432	660	600	555	305	4	50	2440	325	20-34
	500	457	730	660	610	305	4	52	2860	360	20-41
	600	508	840	770	718	305	5	56	3450	425	20-41
	700	610	955	875	815	305	5	60	3960	460	24-48
	800	660	1070	990	930	305	5	64	4550	512	24-48
900	711	1180	1090	1025		5	66	5250	595	28-54	
1000	811	1305	1210	1140		5	68	5870	660	28-58	



# FLAT PLATE GATE VALVE WITH DIVERSION HOLE

## 有导流孔平板闸阀

手动有导流孔平板闸阀

Manual flat gate valve with bank guiding hole

型号model : ( K ) DPZ43F、(K)DPZ44F

PN1.6 ~ 10.0MPa

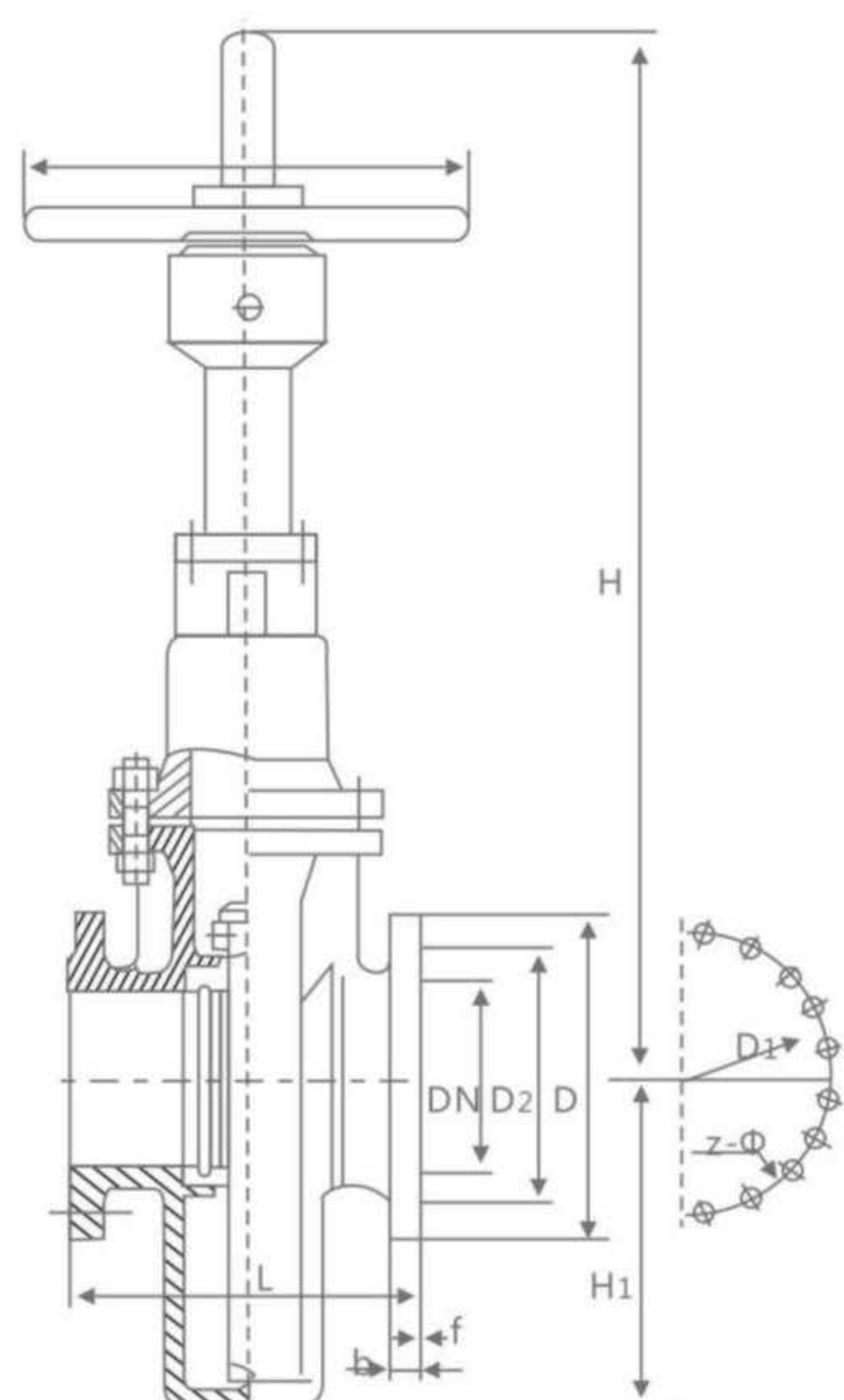

电动有导流孔平板闸阀

Electric flat gate valve with bank guiding hole

型号model : ( K ) DPZ943F、(K)DPZ944F

PN1.6 ~ 10.0MPa

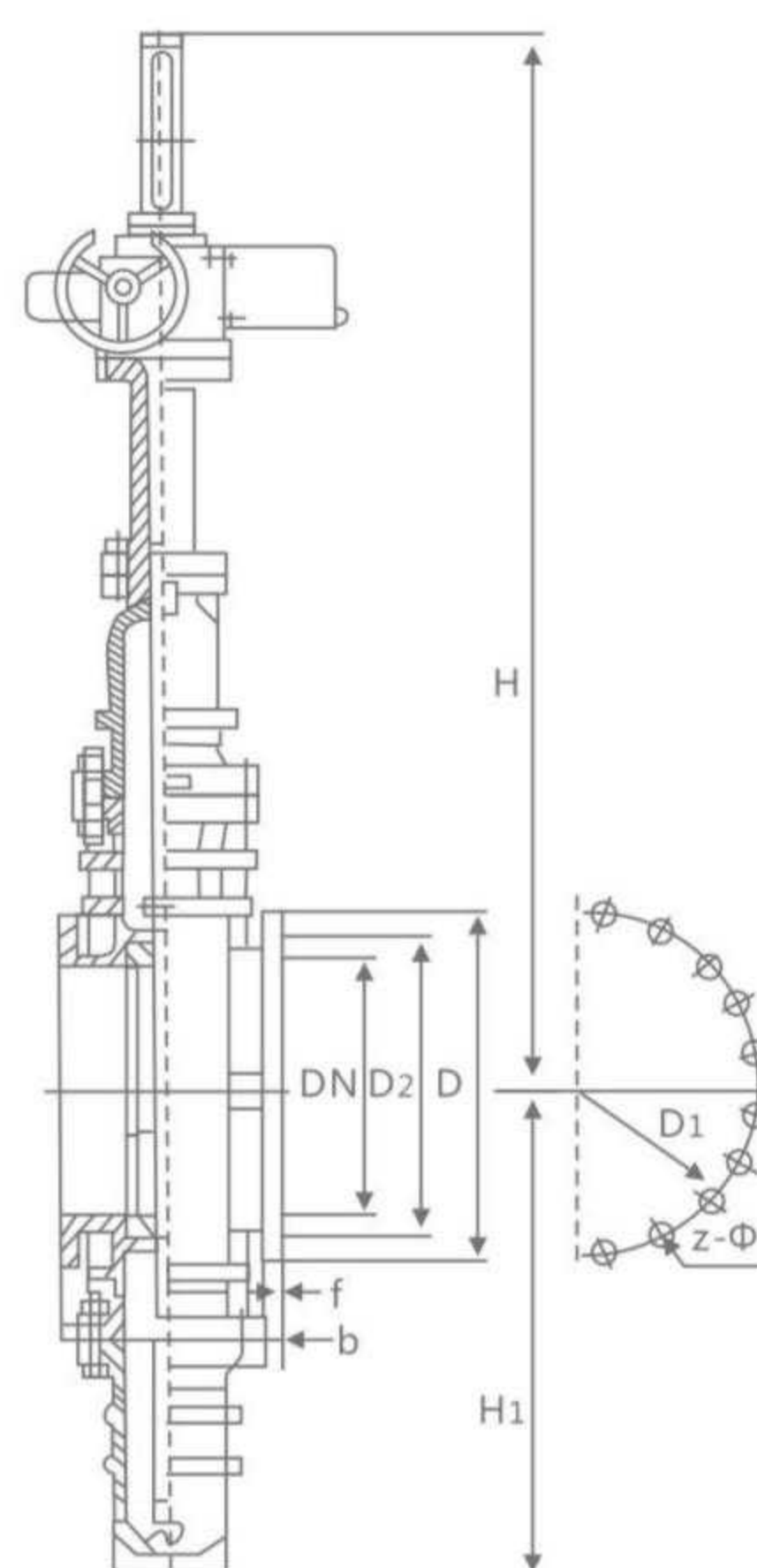

锥齿轮传动有导流孔平板闸阀

Bevel gear transmission flat gate valve with bank guiding hole

型号model : ( K ) DPZ543F、(K)DPZ544F

PN1.6 ~ 10.0MPa

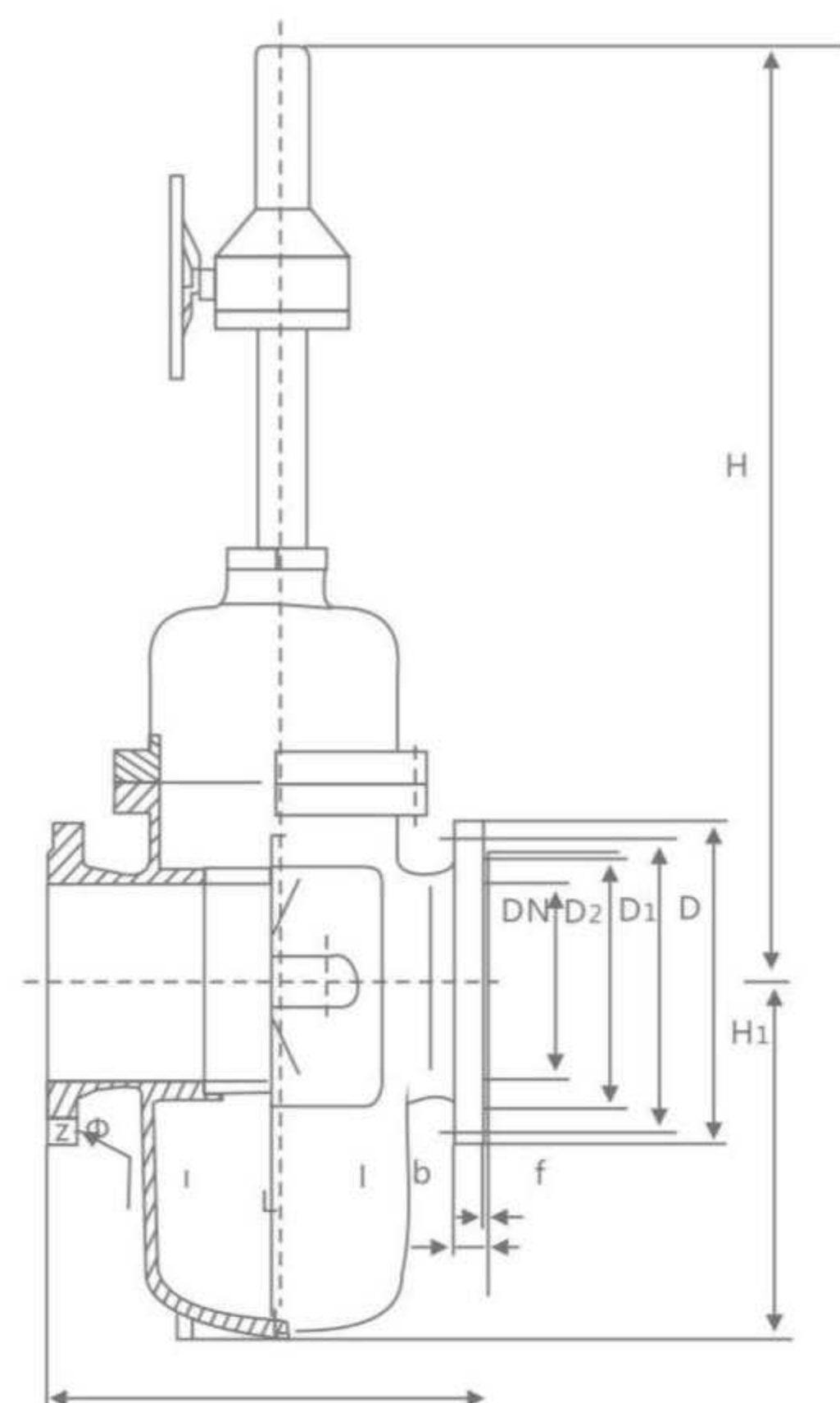

气动有导流孔平板闸阀

Pneumatic flat gate valve with bank guiding hole

型号model : ( K ) DPZ643F、(K)DPZ644F

PN1.6 ~ 10.0MPa

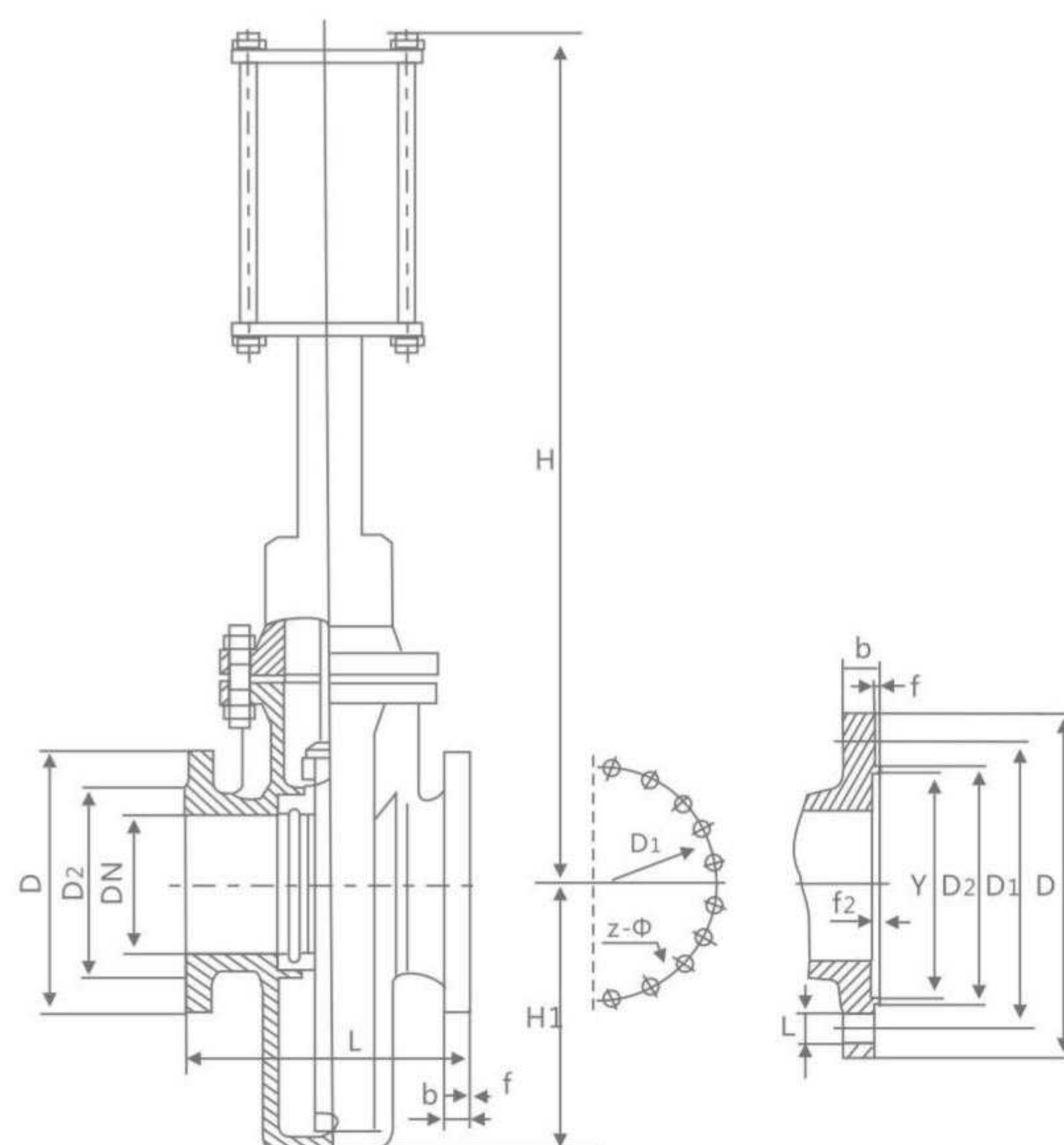

# FLAT PLATE GATE VALVE WITH DIVERSION HOLE

## 有导流孔平板闸阀

主要外形尺寸及连接尺寸 Main external and connection dimension ( JB/T79.1-1994 )

公称压力 PN(MPa)	公称通径 DN(mm)	尺寸Size ( mm )									
		L	D	D1	D2	D0	f	b	H	H1	z-Φ
1.6	50	178	160	125	100	250	3	16	584	8122	4-18
	65	190	180	145	120	250	3	18	634	154	4-18
	80	203	195	160	135	250	3	20	688	169	8-18
	100	229	215	180	155	300	3	20	863	193	8-18
	125	254	245	210	185	350	3	22	940	215	8-18
	150	267	280	240	210	350	3	24	1030	283	8-23
	200	292	335	295	265	350	3	26	1277	352	12-23
	250	330	405	355	320	400	3	30	1491	440	12-25
	300	356	460	410	375	450	4	30	1701	514	12-25
	350	381	520	470	435	500	4	34	1875	602	16-25
	400	406	580	525	485	305	4	36	2180	678	16-30
	450	432	640	585	545	305	4	40	2440	785	20-30
	500	457	705	650	608	305	4	44	2860	855	20-34
	600	508	840	770	718	305	5	48	3450	1045	20-41
	700	610	910	840	788	305	5	50	3960	1190	24-41
	800	660	1020	950	898	305	5	52	4550	1350	24-41
900	711	1120	1050	998		5	54	5250	1510	28-41	
1000	811	1255	1170	1110		5	56	5870	1715	28-48	
2.5	50	178	160	125	100	250	3	20	584	8122	4-18
	65	190	180	145	120	250	3	22	634	154	8-18
	80	203	195	160	135	250	3	22	688	169	8-18
	100	229	230	190	160	300	3	24	863	193	8-23
	125	254	270	220	188	350	3	28	940	215	8-25
	150	267	300	250	218	350	3	30	1030	283	8-25
	200	292	360	310	278	350	3	34	1277	352	12-25
	250	330	425	370	332	400	3	36	1491	440	12-30
	300	356	485	430	390	450	4	40	1701	514	16-30
	350	381	550	490	448	500	4	44	1875	602	16-34
	400	406	610	550	505	305	4	48	2180	678	16-34
	450	432	660	600	555	305	4	50	2440	785	20-34
	500	457	730	660	610	305	4	52	2860	855	20-41
	600	508	840	770	718	305	5	56	3450	1045	20-41
	700	610	955	875	815	305	5	60	3960	1190	24-48
	800	660	1070	990	930	305	5	64	4550	1350	24-48
900	711	118	1090	1025		5	66	5250	1510	28-54	
1000	811	1305	1210	1140		5	68	5870	1715	28-58	

# DZ41Y LOW TEMPERATURE VALVE

## DZ41Y低温闸阀

DZ41Y -16P

### 产品特点 Product features

- 1、为防止中腔异常升压，在闸板的进口侧设置了泄压孔
- 2、根据阀门的工作温度确定阀盖的顶部长度，确保阀杆填料的可靠密封
- 3、根据工作温度合理选用填料，垫片等零件的材料
- 4、严格控制材料的化学成份及低温冲击韧性等力学性能指标
- 5、采用多种配管法兰标准及密封面型式，适用于各种工程需要6低温闸阀适用于甲烷、液态天然气、己烯、二氧化碳、液氨、液氧、液氮、液氢等低温介质

### 产品优点 Product advantages

- 1、流体阻力小，密封面受介质的冲刷和侵蚀小。
- 2、开闭较省力。
- 3、介质流向不受限制，不扰流、不降低压力。
- 4、形体简单，结构长度短，制造工艺性好，适用范围广。

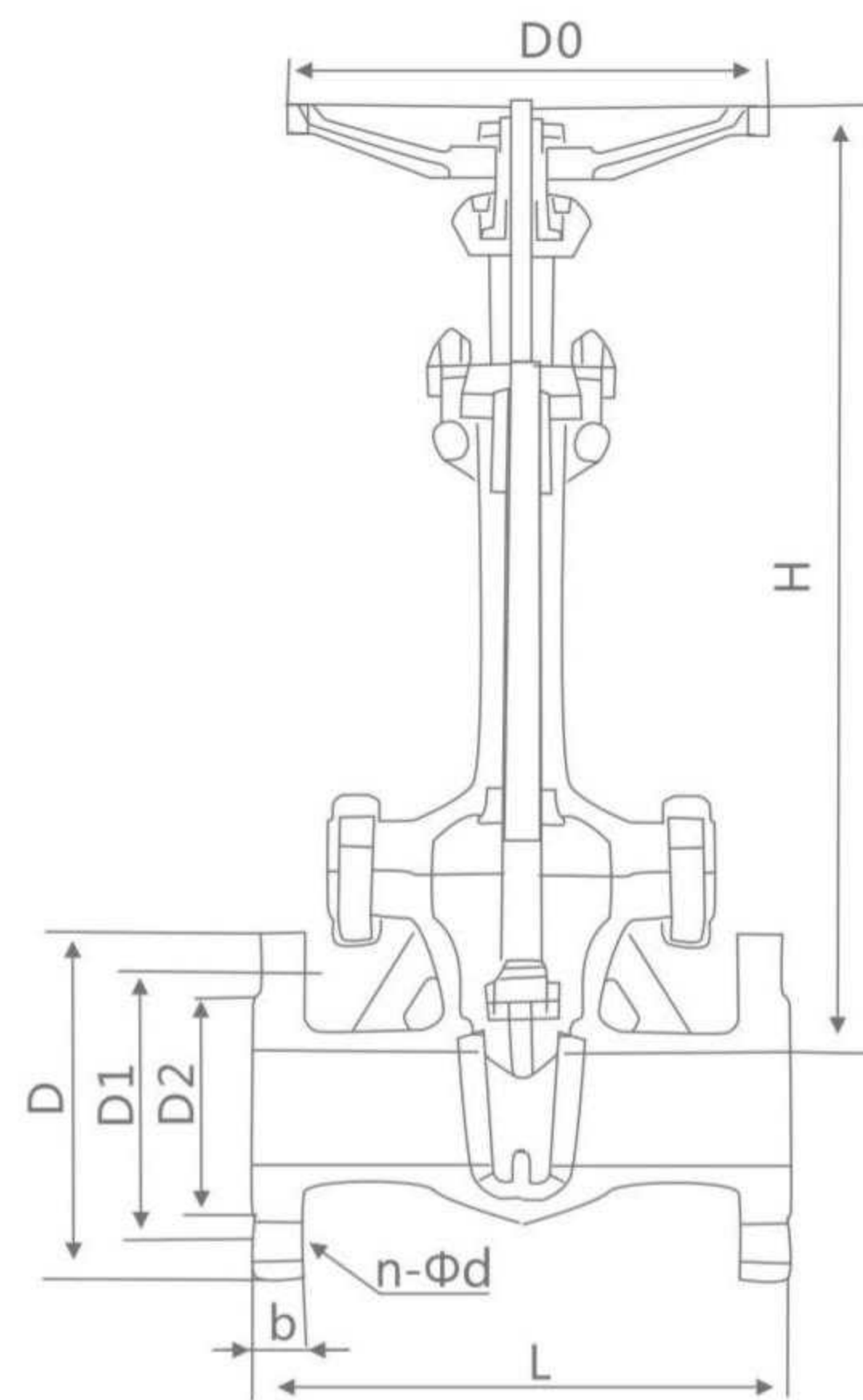

### 执行标准 Execution standard

设计与制造	结构长度	法兰尺寸	压力-温度	试验-检验
JB/T7749	GB12221	JB79	GB9131	JB/T9092

### 压力试验 Pressure test

公称压力PN	1.6	2.5	4.0	6.4	10.0
强度试验	2.4	3.8	6.0	9.6	15.0
水密封试验	1.8	2.8	4.4	7.0	11.0
上密封试验	1.8	2.8	4.4	7.0	11.0
气密封试验	0.4-0.7				

### 主要零件材料及性能 Major parts material and the performance

体盖板	阀杆	密封面	垫片	填料	工作温度	适用介质
ZGoCrMnVAI低温高压铸钢	1Cr7Ni12	STL/STL	PTFE/柔性石墨 PTFE/金属缠绕垫	PTFE	-46	丙烷/丙烯 甲醇/乙烷 煤气/液氨
LCB					-60	
ZGoCrMnVAI低温高压铸钢					-73	
LC2					-101	
ZGoCrMnVAI低温高压铸钢	1Cr18Ni9Ti	-115				
LC3		-196				
ZGoCrMnVAI低温高压铸钢		CF8				

# DZ41HY/F LOW TEMPERATURE VALVE

## DZ41H/Y/F 低温闸阀

### 主要外形尺寸及连接尺寸 Main external and connection dimension

PN16(MPa)

DN	L	D	D1	D2	b	n-Φd	H	DO
20	150	105	75	55	14	4-Φ14	320	140
25	160	115	85	65	14	4-Φ14	350	160
32	180	135	100	78	16	4-Φ18	385	180
40	200	145	110	85	16	4-Φ18	420	220
50	250	160	125	100	16	4-Φ18	540	240
65	265	180	145	120	18	4-Φ18	610	240
80	280	195	160	135	20	8-Φ18	690	280
100	300	215	180	155	20	8-Φ18	780	300
125	325	245	210	185	22	8-Φ18	930	320
150	350	280	240	210	24	8-Φ23	980	350
200	400	335	295	265	26	12-Φ26	1180	400
250	450	405	355	320	30	12-Φ30	1390	450
300	500	460	410	375	30	12-Φ30	1620	500
350	550	520	470	435	34	16-Φ34	1810	500
400	600	580	525	485	36	16-Φ36	1970	550

PN25(MPa)

DN	L	D1	D1	D2	b	N-Φd	H	DO
20	150	105	75	55	16	4-Φ16	320	140
25	160	115	85	65	16	4-Φ16	350	160
32	180	135	100	78	18	4-Φ18	385	180
40	200	145	110	85	18	4-Φ18	420	200
50	250	160	125	100	20	4-Φ20	540	240
65	265	180	145	125	22	8-Φ22	510	240
80	280	195	160	135	22	8-Φ22	690	280
100	300	230	190	160	24	8-Φ24	780	300
125	325	270	220	188	28	8-Φ28	930	300
150	350	300	250	218	30	8-Φ30	980	320
200	400	360	310	278	34	12-Φ34	1180	360
250	450	425	370	332	36	12-Φ36	1390	400
300	500	485	430	390	40	16-Φ40	1620	450
350	550	550	490	448	44	16-Φ44	1810	500
400	600	610	550	505	48	16-Φ48	1990	560

# DZ41H/Y/F LOW TEMPERATURE VALVE

## DZ41H/Y/F 低温闸阀

### 主要外形尺寸及连接尺寸 Main external and connection dimension

PN40(MPa)

DN	L	D	D1	D2	D6	b	N-Φd	H	Do
20	150	105	75	55	51	16	4-Φ14	330	140
25	160	115	85	65	58	16	4-Φ14	360	160
32	180	135	100	78	66	18	4-Φ18	440	180
40	200	145	110	85	76	18	4-Φ18	455	200
50	250	160	125	100	88	20	4-Φ18	575	240
65	380	180	145	120	110	22	4-Φ20	635	240
80	3103	195	160	135	121	22	8-Φ22	715	280
100	50	230	190	160	150	24	8-Φ22	815	300
125	400	270	220	188	176	28	8-Φ24	965	360
150	450	300	250	218	204	30	8-Φ28	1025	400
200	550	375	320	282	160	38	8-Φ30	1225	450
250	650	445	385	345	313	42	12-Φ34	1440	560
300	750	510	450	408	364	46	16-Φ34	1665	5470
350	850	570	510	465	422	52	16-Φ41	1880	720
400	950	655	585	535	474	58	16-Φ18	2050	800

PN64(MPa)

DN	L	D	D1	D2	D6	b	N-Φd	H	Do
20	190	125	90	68	51	20	4-Φ18	330	180
25	210	135	100	78	58	22	4-Φ23	360	180
32	230	150	110	82	66	24	4-Φ23	410	180
40	240	165	125	95	76	24	4-Φ23	480	220
50	250	175	135	105	88	26	4-Φ23	585	240
65	280	200	160	130	110	28	8-Φ23	690	240
80	310	210	170	140	121	30	8-Φ23	745	280
100	350	250	200	168	150	32	8-Φ25	885	300
125	400	295	240	202	176	36	8-Φ30	985	360
150	450	340	280	240	204	38	8-Φ34	1050	400
200	550	405	345	300	260	44	12-Φ34	1240	450
250	650	470	400	352	313	48	12-Φ41	1460	560
300	750	530	160	412	364	54	16-Φ41	1670	5640

# NON-RISING STEM GATE

## Z45H/W 暗杆闸阀

Z45<sup>W</sup>-16C、P、R

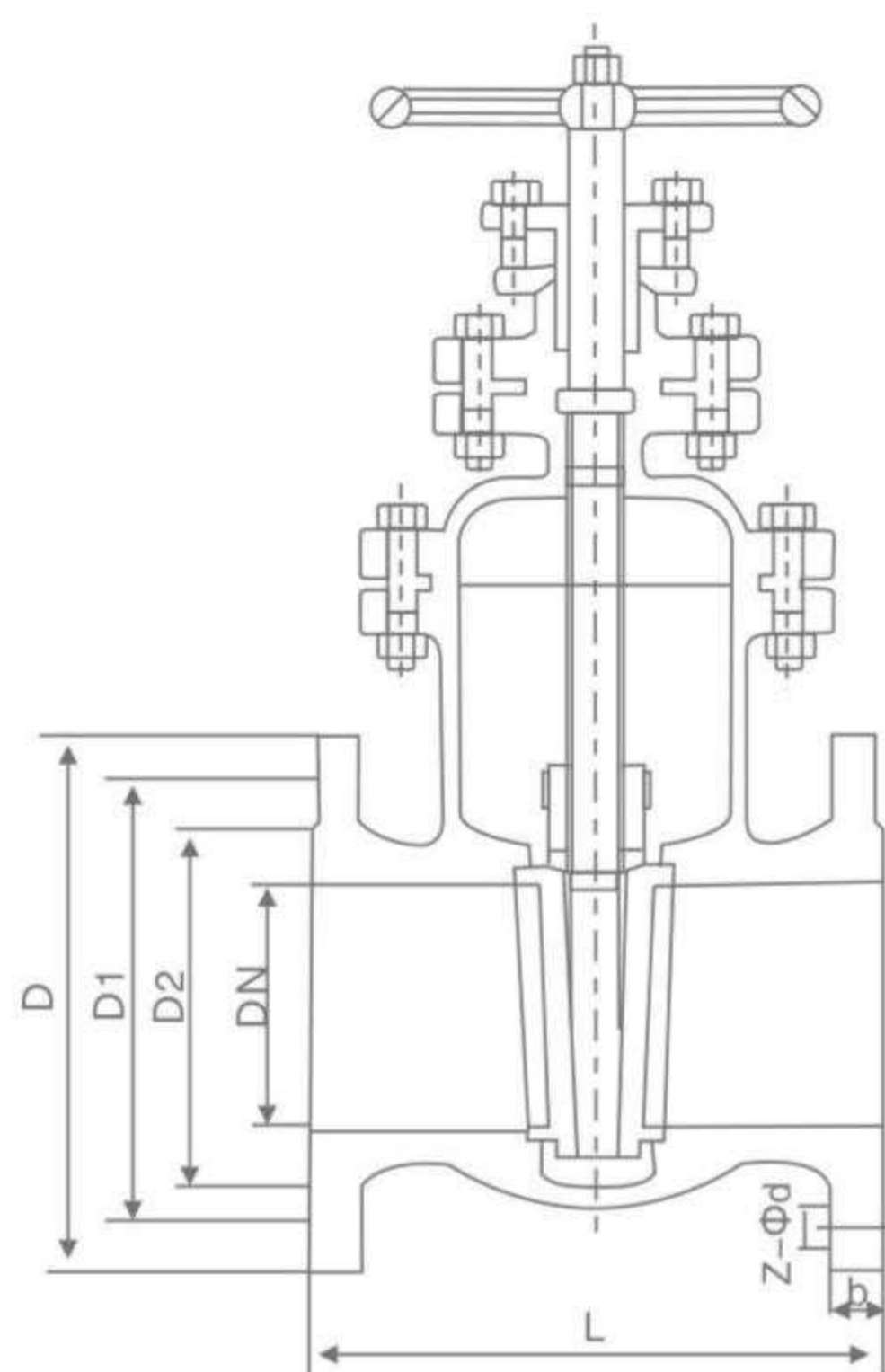

### 技术参数 Technical parameters

压力等级 Pressure rating	阀体耐压 Body voltage	密封试验 Seal test	工作温度 Working temperature	适用介质 Suitable medium
1.0MPa、1.6MPa	1.5MPa、2.4MPa	1.1MPa、1.76MPa	0~80°C	水、气等 water, gas, etc

### 主要零件材料 Main components material

名称 Name	材料 Material								
阀体/阀盖 Body/Bonnet	CF8	CF3	CF8M	CF3M	WCB	LCB	WC6	WC9	C5
闸板 Wedge	CF8	CF3	CF8M	CF3M	WCB	LCB	WC6	WC9	C5
阀杆 Stem	F304	F304L	F316	F316L	2CR13	F304	F304	F304	F304
阀杆螺母 Stem Nut	铝青铜 Aluminium Bronze								
填料 Packing	PTFE/柔性石墨				石墨 Graphite				
垫片 Gasket	PTFE/金属缠绕垫				石墨 Graphite				
压盖 Gland	CF8	CF3	CF8M	CF3M	WCB	LCB	WC6	WC9	C5
螺栓 Bolt	不锈钢 Stainless Steel				35CrMoA				
螺母 Nut	不锈钢 Stainless Steel				45、35CrMoA				
手轮 Handwheel	铸钢 Cast Steel								

### 主要尺寸 Main dimensions

公称通径 DN(mm)	尺寸 Dimensions (mm)					
	L	D	D1	D2	b	Z-Φd
50	250	160	125	100	16	4-18
65	265	180	145	120	18	4-18
80	280	195	160	135	20	8-18
100	300	215	180	155	20	8-18
125	325	245	210	185	22	8-18
150	350	280	240	210	24	8-23
200	400	335	295	265	26	12-23
250	450	405	355	320	30	12-25
300	500	460	410	375	30	12-25
350	550	520	470	435	34	16-25
400	600	580	525	485	36	16-30